

**USER'S MANUAL**  
**NEXTorr PUMP POWER SUPPLY**  
**NIOPS-03**

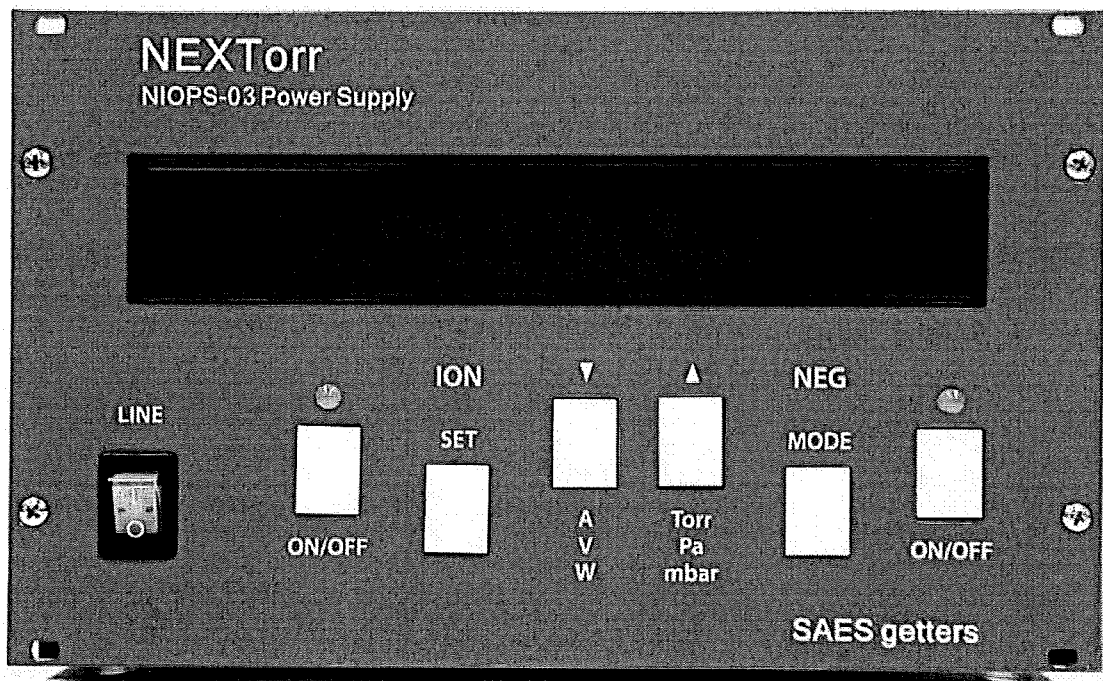

SAES ADVANCED TECHNOLOGIES S.p.A. – Italy  
[www.saesgetters.com](http://www.saesgetters.com)

"The Nextorr® product line has global Intellectual Property Rights coverage with patents already granted in the US (8,287,247), Europe (2,409,034), Japan (5,372,239), China (102356236)".

NEXTorr is an International Registered Trademark in the name of SAES Getters S.p.A.

---

The **NEXTorr NIOPS-03** power supply serves for operating the **NEXTorr D 100-5** and **NEXTorr D200-5** pumps. It is designed to be used indoor in laboratory conditions.

**WARNING**

After transportation, the device has to be left idle without mains voltage for at least 3 hours at the laboratory

**Security provisions**

**ATTENTION**

Inside the instrument and also in the connector and cable for the ion pump connection, a high voltage is present which is capable of causing a casualty even without any direct touch.

**Manipulation the high voltage cable and also of the grounding wire is prohibited during the course of the supply operation.**

**Likewise, the supply operation without protective covers is prohibited.**

Protect the device against humidity and against penetration of conductive objects and liquids into the ventilation slots.

**Symbols on the Product**

These symbols appear on the product:



**WARNING**  
High voltage



Ground  
terminal



**CAUTION**  
Refer to  
manual

---

## INDEX

1. APPLICATION .....	5
2. INTRODUCTION .....	5
2.1. General description.....	5
2.2. Simplified block scheme .....	6
2.3. Scheme connections Instrument.....	6
2.4. The front panel of the unit.....	7
2.5. The rear panel of the unit.....	8
2.6. Instrument Dimensions .....	9
3. INSTALLATION .....	10
3.1. Mounting operation .....	10
3.2. Electrical connections .....	11
4. OPERATIONS .....	12
4.1. Start operations.....	12
4.2. Operating IP supply .....	12
4.3. Operating NP supply.....	13
4.4. Operating IP and NP supply in case of line interruption .....	14
5. CHANGE OF IP SETTINGS .....	15
6. SERVICE MODE IP .....	16
7. SERVICE MODE NP .....	17
8. THE OUTPUT CONNECTOR FUNCTION .....	18
8.1. IN/OUT Interface.....	18
8.2. Analog Output.....	20
8.3. RS232/485 Interface .....	21
9. CONTROL VIA A SERIAL CHANNEL .....	22
9.1. Definition.....	22
9.2. Communication protocol for RS232 .....	22
9.3. The transmission protocol.....	23
9.4. Service of failures .....	23
9.5. The commands used .....	24
9.6. Communication protocol for RS485 MODBUS RTU .....	29
10. MAINTENANCE AND TROUBLESHOOTING.....	33

---

10.1.	NP troubleshooting.....	33
10.2.	IP troubleshooting .....	34
11.	SPECIFICATIONS.....	36
12.	INSTRUCTION FOR INSTRUMENT DISPOSAL.....	37
13.	PRODUCT CONFIGURATIONS AND ACCESSORIES.....	38
14.	WARRANTY CONDITIONS .....	39
15.	SERVICE.....	40
15.1.	Sales & Service Locations: .....	40

---

## 1. APPLICATION

The **NEXTorr** power supply, model **NIOPS-03**, is designed for operating the **NEXTorr D 100-5** and **NEXTorr D 200-5** pumps.

## 2. INTRODUCTION

### 2.1. General description

The device consists of two power units incorporated in one frame. The former power unit controls the ion pump (**IP**), while the latter is designed for non evaporable getter pump (**NP**). Both units utilize mutual line power module and they are controlled by a microprocessor circuit.

The **IP** supply unit is based on a “flyback” type voltage converter, which works at 20 kHz frequency. The converter operation principle, in combination with the circuit configuration of the power supply, produces V–A characteristics suitable to operate the ion getter pumps.

The **NP** supply unit is a voltage controlled power supply designed to operate at low resistance loads. The supply is based on forward switching convertor to which are added measuring and protective circuits.

Both supplies are controlled by a microprocessor unit which enables to set working mode, measure output current and power, protect supply against overheat, short and open circuit, display parameters and communicate with external facilities via serial channel.

The two power units can operate independently. In some case the **NP** and **IP** can operate coupled in safety condition.

Most of functions and parameters can be controlled and read via serial communication protocol RS232 ASCII or RS485 MODBUS RTU.

## 2.2. Simplified block scheme

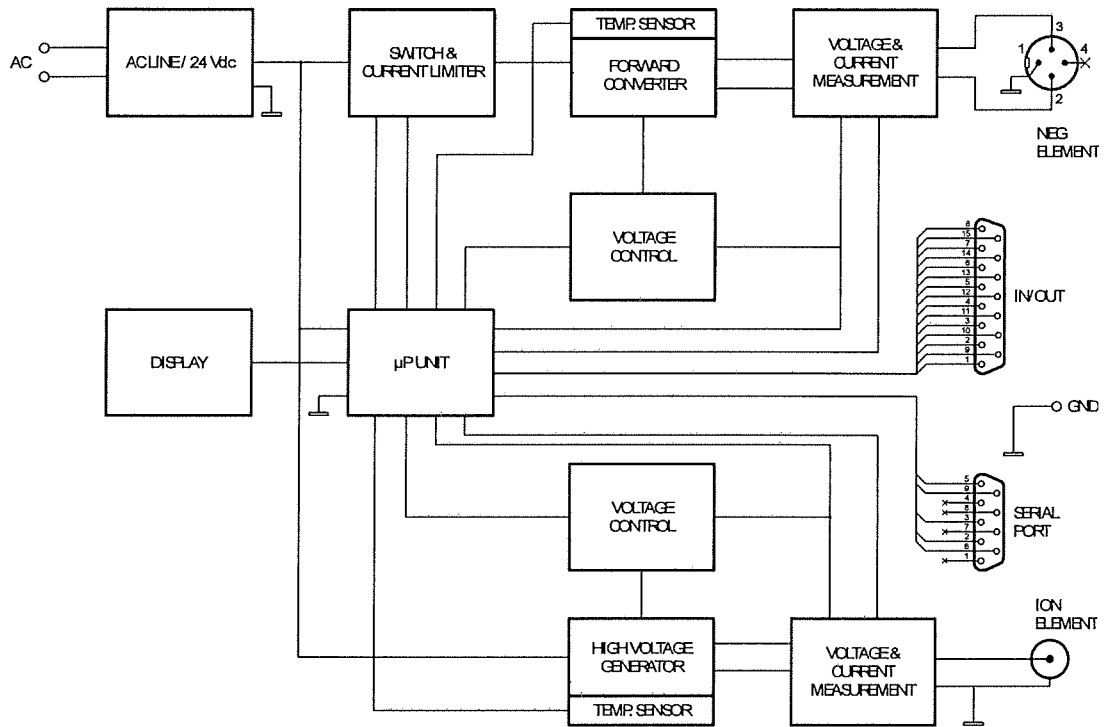

## 2.3. Scheme connections Instrument

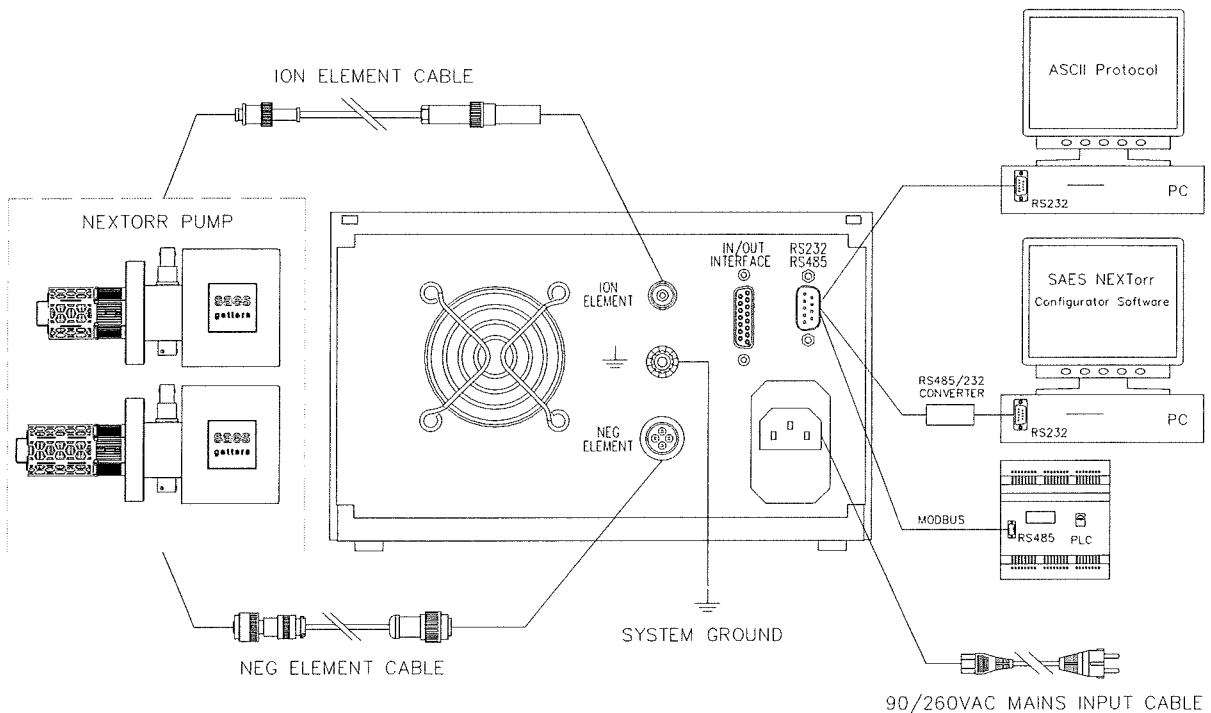

## 2.4. The front panel of the unit

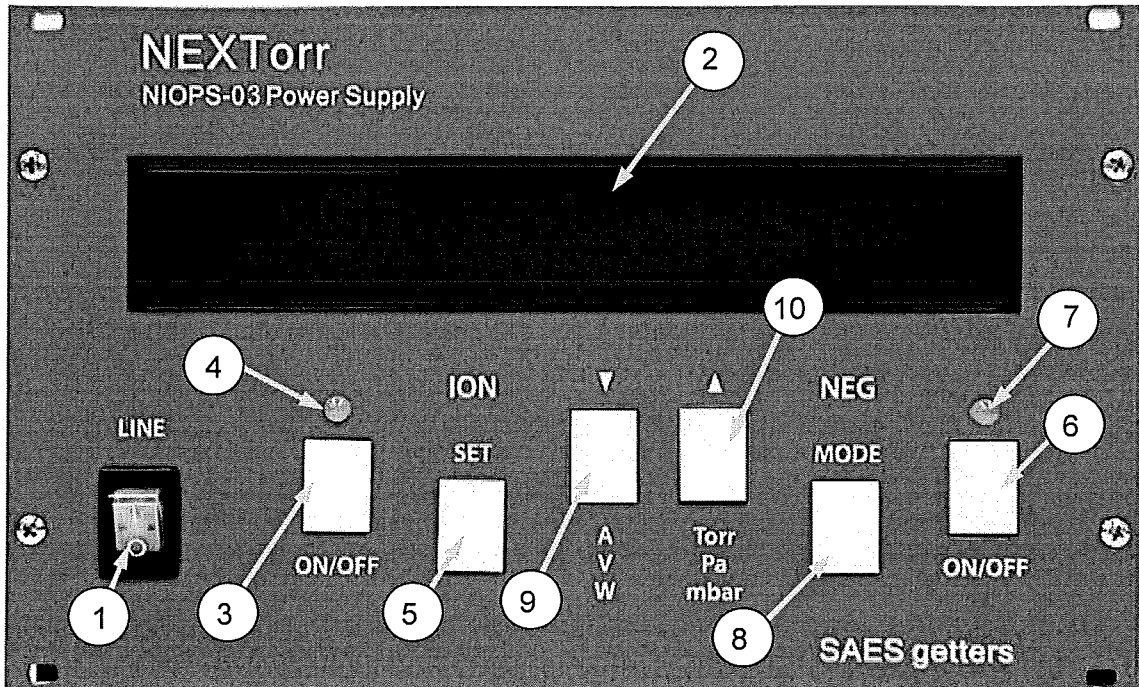

### Items of front panel for common purpose:

1. the mains voltage switch **LINE**,
2. alphanumeric two line display.

### Items of front panel for **IP** supply purpose (situated below inscription **ION**):

3. pushbutton **ON/OFF**,
4. red/green/yellow led indicator,
5. pushbutton **SET**.

### Items of front panel for **NP** supply purpose (situated below inscription **NEG**):

6. pushbutton **ON/OFF**,
7. red/green/yellow led indicator,
8. pushbutton **MODE**.

### Items of front panel for both **IP** and **NP** purpose:

9. pushbutton **A/V/W/▼**,
10. pushbutton **Torr/Pa/mbar/▲**.

## 2.5. The rear panel of the unit

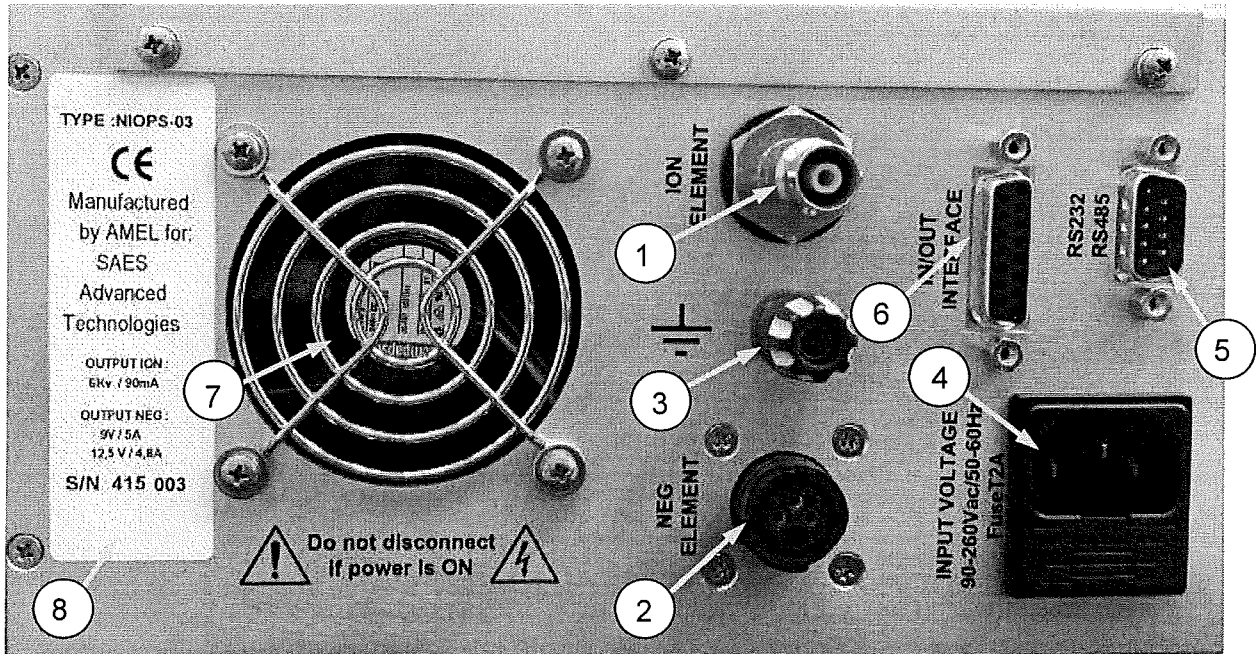

### Items of rear panel:

1. output HV connector **ION ELEMENT** for connection of IP,
2. output connector **NEG ELEMENT** for connection of NP,
3. ground terminal  $\perp$ ,
4. mains plug combined with fuse holder and fuse T 2A,
5. **RS232/RS485** communication connector,
6. **IN/OUT INTERFACE** connector (connection of the output and control signals),
7. protected outlet of an inbuilt fan
8. data label of the instrument.



## 2.6. Instrument Dimensions

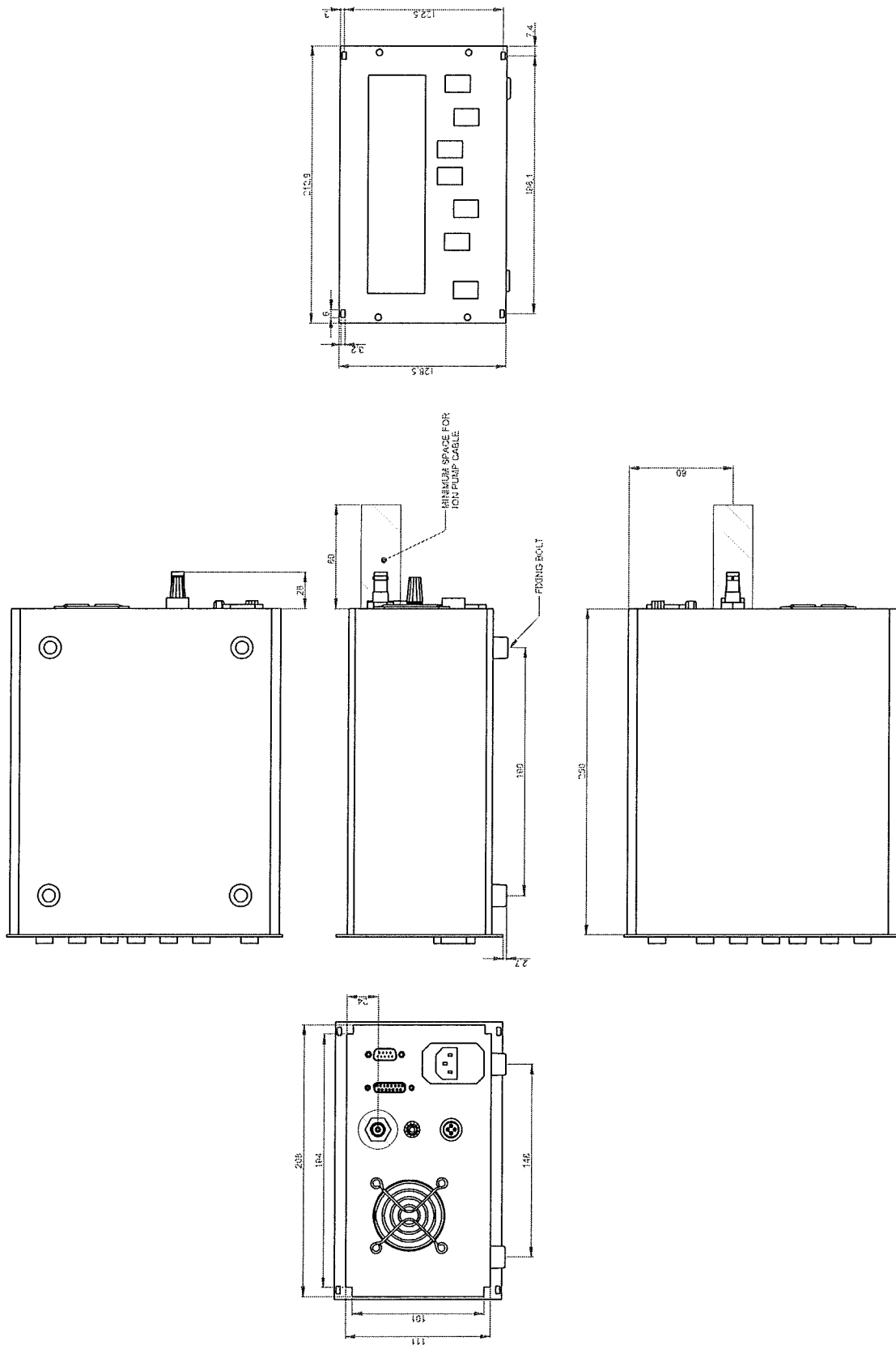

---

### 3. INSTALLATION

#### 3.1. Mounting operation

Construction design enables the unit to operate either as a stand-alone version (to be laid on a table) or as a system version which can be mounted in a rack (rack 3U 19" installation with M3 screws). Accordingly of desired version it is possible to mount/remove four rubber feet. The feet are fastened by means of their bolts

##### Stand-alone version

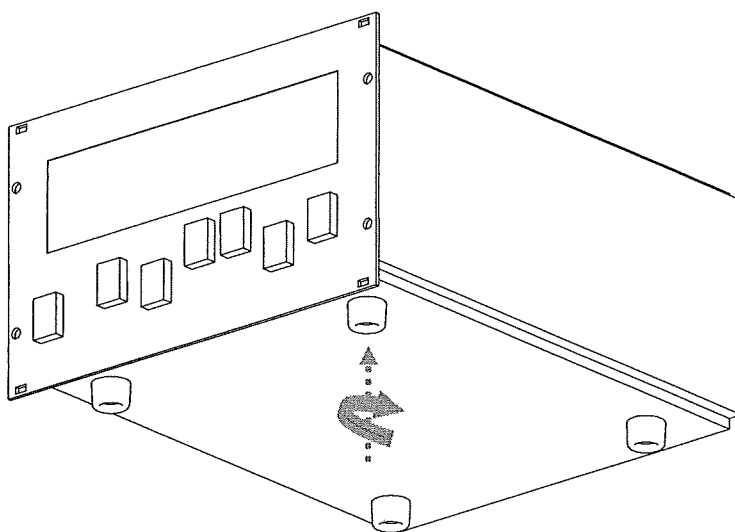

##### Mounting on panel

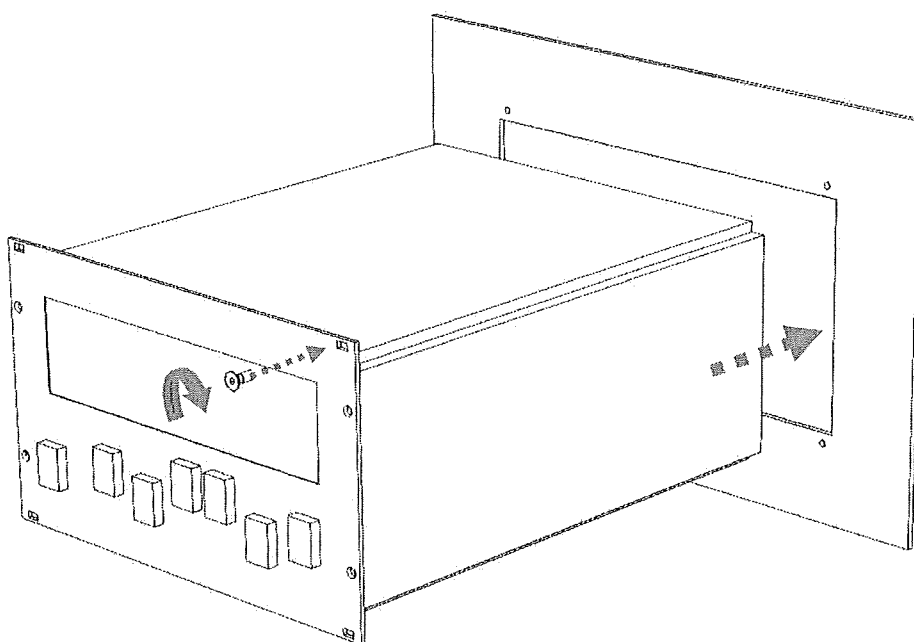

**Note:** the circulation of cooling air on the upper and bottom side and behind the device must not be significantly limited when the unit is inserted in a rack or laid on a table.

---

## 3.2. Electrical connections

The **IP** is connected to the power supply by means of the provided high voltage cable. The appropriate cable terminal is inserted into the high voltage connector labeled **ION ELEMENT**. The cable is locked by rotating the ring against spontaneous disengagement. The same operation must be done for the opposite end of the cable on the pump side. When connecting, it is necessary to check carefully whether a reliable contact is secured between the frame of the pumping system and the outer electrode of the high voltage connector (by means of the screening braid of the high voltage cable). For security reasons it is necessary to interconnect the pumping system frame with the supply ground terminal  $\perp$  by using a protective cable. The protective coupling must be done by a conductor with a cross-sectional area of min. 0.75 mm<sup>2</sup> and maximum length of 20 m.

The protective mains wire and the ground terminal  $\perp$  or the outer electrode of the high voltage connector are not mutually galvanically interconnected. They are separated by means of protective diodes which become conductive if the voltage between the protective wire and the  $\perp$  terminal exceeds 0.7 V.

The **NP** is connected to the power supply unit by the 3-wire cable provided, inserting it in the **NEG ELEMENT** connector. Connectors on both sides of the cable must be locked against spontaneous disengagement by rotating their rings.

The enclosed plug DB 15 (Interlock) with junctions (shorted pins 6-9 and 1-14) should be inserted to connector **IN/OUT** on the rear panel or the junctions may be replaced by a suitable system of safety switching off (see Sec. 8).

### **Warning**

Connection and disconnection of the high voltage cable are possible only with the power supply switched off.

---

## 4. OPERATIONS

### 4.1. Start operations

The supply is switched on by pressing the **LINE** switch into position **I**; the connection is signaled by the green light of the switch. The **IP** and **NP** are not electrically powered (see *Sec. 4.2* and *4.3* for the operating conditions).

The messages *Wait...* on first line and *NEXTorr D100-5* or *NEXTorr D200-5* on second line are displayed during device initiation for a short time. During this time the **NP** outer electrical circuit is tested. The message on the second line show the NEXTorr pump selected. To change the selection, see *Sec. 7*.

If the interlock plug is not inserted or some of the junctions are interrupted, the display will show the message *Disabled!* on both lines of the display (see *Sec. 8.1*).

When the initiation process is successfully over the display will show on the first line an message: *I Ready...* and on the second line: *N Ready... Mode?*

The both indicators above **ON/OFF** pushbuttons will light red (providing the previous state before the line was switched off had been **OFF**).

If the outer circuit of **NP** is not all right, the display shows *Open!* (for interrupted circuit) or *Short!* (for short circuit between heating element of NEG and frame). These messages will appear with a delay of several seconds and the indicator in **NEG** section will start blinking yellow.

The first line of the display starts with letter *I* and is devoted to the states and parameters of **IP** supply. The second line starting with letter *N* will show states and parameters of **NP** supply.

### 4.2. Operating IP supply

The **IP** supply can be switched on by pressing the pushbutton **ON/OFF** in the section **ION**. The unit must be switched on only at the recommended starting pressure (see pumps *Operating Instruction Manual* for details). The working state of the supply is indicated by green light led above the mentioned pushbutton.

The current flowing through the pump can be read from the front panel display. Sometime after switching-on the **IP** supply unit, a character in the form ↓ or ↑ may appear on the left hand side of the display. This symbol expresses a systematic trend (approx. during last 30 to 45 s) in the pump current variation – increasing or decreasing. If no arrow is displayed, it means that the current is more or less stable. The pump voltage, output power and pump current can be alternatively displayed by pushing the pushbutton **A/V/W**.

Pushing the button **Torr/Pa/mbar** will sequentially display the pump pressure value in this units. The relationship between the value of the current and pressure is dependent on the type and size of used pump. To set the values see *Sec. 5*. The relationship between current and pressure may be dependent also of the instantaneous pump voltage. It is noteworthy that the pressure value calculated from the pump current value has to be considered as rough indication (especially at very low pressure when a leakage pump current may occur). An \* (asterisk) shows up when IP current reaches 0 nA (IP current is below the measurable limit).

#### **Warning**

In the case the HV cable is disconnected, the current will be 0 and the asterisk will show up as well.

The device is equipped with an automatic overcurrent protection which switches off the **IP** supply (the high-voltage part) after the pump current exceeds the safety value protection adjusted under **1H** (see *Sec. 5*), which is indicated by yellow blinking of the indicator above **ON/OFF** pushbutton.

---

At the same time an acoustic signal and the word *Overload* will appear on the display. After 3+5 seconds the supply automatically switches on again. If the overcurrent protection level is exceeded once again, the device switches off repeatedly. After 3 unsuccessful attempts to switch on the supply automatically, the supply switches off permanently and the yellow blinking indicator and acoustic signal sound do not stop. To switch-on the **IP** supply unit, press down on the ON/OFF button. The ON/OFF button must be held pressed until the current decreases below the current level set in **1H**.

If the pump current at repeated attempts to switch on reaches 90 mA value the supply remains permanently switched off and the sign *Error!* will appear on the display. The only possible exit from this state is to switch off the whole unit from the mains switch **LINE**. After the cause of excessive current is removed (e.g. getting a better vacuum or removing a short circuit) it is possible to switch on the unit again.

These functions protect the supply against an excessive load but also protect your pump against an uncontrolled operation, which could damage it or shorten its lifetime.

The supply is equipped with three comparators-switches of the pump current/pressure. The function of the first one, labeled **1**, was described in the previous paragraph. The other two, **2** and **3**, serve for the needs of customers who are not going to use a computer to control the pumping process or it is possible to incorporate their outputs to hardware system of related appliances. Their outputs are led to the **IN/OUT** output connector and the characters depicted on the last two positions of the display first line simultaneously indicate their function. The *L* letter lights up when the pump current/pressure is lower than the adjusted values while the *H* letter lights up if the current/pressure exceeds the pre-set value. Comparators-switches **2** and **3** can work in **Simple regime** or in **Window regime**. To change regime see *Sec. 5*.

### Simple regime

If the current/pressure is between preset **L** and **H** values, the state of the indicator and output switch of related comparator depends on the sense of current/pressure change. The *L* symbols and closed contacts on output connector will stay unchanged until current/pressure value exceeds **H** value and *H* symbols and unclosed contacts will stay unchanged until current/pressure value goes under preset **L** value. The hysteresis switching on / off is given by adjusted values **L** and **H**.

### Window regime

If the current/pressure is between **L** and **H** values, the indicators of related comparator will show letter *W*. The output of the comparator is composed by a pair of contacts which are disconnected if the current/pressure is lower than preset level **L** or is higher than preset level **H**. Inside the interval **L–H** the output contacts are connected. The hysteresis of switching on when current/pressure is increasing over the level **L** is automatically set to a value by 10 % higher and when decreasing below value **H** by 10 % lower level. This circumstance must be taken into consideration when setting levels **L** and **H**.

The pin layout of the output connector is described in the *Sec.8*.

**Note:** When the current range in the instrument is changed with the upper value of 1 mA or 10  $\mu$ A, the function of output switches is delayed by several seconds.

## 4.3. Operating NP supply

The message *Ready... Mode?* on the second line of the display appears if the **NP** is properly connected. From this point on, it is possible to choose one of four working modes by pressing the pushbutton **MODE**:

- **Activation:**

NEXTorr D100-5 - the supply delivers 9 V/ 5 A continuously and full power 45 W

NEXTorr D200-5 - the supply delivers 12,5 V/ 4,8 A continuously and full power 60 W

---

- 
- **Tmd Activation** – (timed activation):  
NEXTorr D100-5 - the supply delivers 9 V/ 5 A and full power 45 W for 1 hour  
NEXTorr D200-5 - the supply delivers 12,5 V/ 4,8 A and full power 60 W for 1 hour
  - **Conditioning**:  
NEXTorr D100-5 - the supply delivers approx. 4.5 V and 25 % of full power  
NEXTorr D200-5 - the supply delivers approx. 6 V and 25 % of full power
  - **Tmd Conditioning** – (timed conditioning):  
NEXTorr D100-5 - the supply delivers approx. 4.5 V and 25 % of full power for 1 hour  
NEXTorr D200-5 - the supply delivers approx. 6 V and 25 % of full power for 1 hour

Each chosen mode can be started by pressing **ON/OFF** pushbutton in **NEG** section and interrupted again by pressing **ON/OFF** pushbutton. The output voltage after start rises slowly to prevent inrush current to cold heating element. Timed modes are automatically ended after 1 hour.

When the supply unit is operating (after **ON/OFF** pushbutton is pressed) the display shows an abbreviation of working mode, delivered power, elapsed time and count of failures:

- *Act* – stands for activation,
- *TdAct* – stands for timed activation,
- *Con* – stands for conditioning,
- *TdCon* – stands for timed conditioning.

The displayed value of delivered power is the power on input terminals of **NP**. This value of power is calculated, from the power measured on the output terminals of the supply (where voltage and current are measured) subtracted the voltage drop caused from the resistance of the cable. For this reason the power obtained as a product of voltage and current (see Sec. 7) is different from the displayed one. The above mentioned compensation is valid only for properly set cable length, when using another cable the accuracy reading of the power would be changed.

The last two positions of the display second line are devoted to failure counter. If a failure has occurred, a symbol of # following by number of failure would appear. When no failure was indicated, the mentioned two symbols stay blank. The failure counter increases only when the failure occurs during on-state.

#### 4.4. Operating IP and NP supply in case of line interruption

Both power supplies can operate singly or together according to user's selection. In case of interruption of line voltage, and then after its restoration, both power supplies try to continue their previous activity. However, before the activity of **NP** is restored the vacuum condition in the chamber must be checked. For this purpose the **IP** is always switched on and after 40 seconds of activity the value of **IP** current is measured. The current value is compared with two preset values – **Low curr** and **High curr**. If the current value lies between the two preset limits, the **NP** power supply is switched on and the **IP** power supply is switched off (or it stays in *on* position to preserve the previous state). If this condition is not fulfilled both **IP** and **NP** power supplies will stay switched off and a message *Bad Vacuum!* will appear on second line of display. For setting **Low** and **High current limit** see Sec. 7.

Should the **NP** activity be interrupted by a lack of power, the operation state will not be lost. When the power is recovered, the **IP** and **NP** will automatically re-start from the last state before the failure. The automatic procedure is describes above.

If either **NP** or **IP** are not in working conditions, it is necessary to switch off them manually by means of **ON/OFF** pushbuttons.

---

## 5. CHANGE OF IP SETTINGS

The comparison level for the overcurrent protection circuits (**1H**) and of the additional two comparators (**2L**, ...**3H**) have been introduced in *Sec. 4.2*. These and the final high voltage value are adjustable by the user according to his needs. To enable the changes of setting, the function must be unlocked (see *Sec. 6*). If frequent changes of setting are not assumed, it is advisable to lock the setting function to prevent an unintentional change.

After the **SET** key is pushed, the editable variables are displayed. Each of them is accompanied by the additional information: *inscription Set*, *the label of comparison level* (e.g. 1H – 1st comparator, overcurrent level) and its *value* (with the measuring units). The pressure units are not displayed.

Providing it is necessary to change the value then press key ▲ or ▼. Further pressing the **SET** key changes the set function to following levels of the comparators (**2L**, ..., **3H** – 3<sup>rd</sup> comparator, high level). Maximal possible adjusted value of current is 89.9 mA. Minimum possible adjusted value is 5 nA. Returning to the measurement mode is possible either through a sequence of steps with the help of the **SET** key behind the last adjustable level or by leaving any value unchanged for longer than 5 seconds.

The adjustment of levels is possible in the pressure measurement regime too. Setting acts in those pressure units where the **SET** key was pushed.

The change of high voltage value is possible in voltage measurement regime. Press the **SET** key and then just press key ▲ or ▼ to arrange high voltage value. The range of adjustment is 1.2÷6 kV with 50 V step. Return to the measurement mode is possible either by pressing **SET** key or by leaving set value unchanged for longer than 5 seconds.

Then the output voltage keeps this value with accuracy  $\pm 50$  V providing that the output power does not overcome maximal possible value of the source.

### Note:

The measurement of high voltage and derived output power only has an informative purpose. The voltage measurement error can reach up to 50 V. All pre-set values are stored even if the device is switched off.

---

## 6. SERVICE MODE IP

The service mode gives useful information about the operation of the device and it enables the change of some working parameters.

The service mode is initiated by simultaneous pressing of pushbuttons **A/V/W, Torr/Pa/mbar** and with slight delay **ON/OFF** in **ION** section. A message *Service mode* will appear on the display. The following pressing of **SET** key will show on the display:

- a) Worked out time of **IP** supply and **NP** supply.
- b) Internal temperature of **IP** and **NP** power supply.
- c) Magnitude of converting constant for recalculation from current to pressure. It is possible to change this constant by means of keys ▲ or ▼ in the range 20 to 4000 A/Torr. Resulting readings of pressure in different units will be influenced as well.
- d) *Contrast* - contrast setting of the characters of the display. This constant can be set by means of keys ▲ or ▼ in the extent 0 to 255. The criterion of setting is a subjective judgment of contrast (standard value is 175).
- e) *Brightness* – a constant expressing the brightness of indicators. This constant can be set by means of keys ▲ or ▼ in the extent 1 to 7. In this regime all indicators are alight. The criterion of setting is a subjective judgment of brightness (standard value is 3).
- f) *SW lock* – lock of adjustment comparators-switches. The key ▲ sets the state **ON** (locked), the key ▼ sets the state **OFF** (unlocked) – it enables the adjustment of levels **1H** to **3H**, output voltage **U** and working regime of comparators-switches **2** and **3**.
- g) *SW2 W mode* – switch of working regime of comparator-switch **2**. The key ▲ sets the state **ON** (**Window regime**), the key ▼ sets the state **OFF** (**Simple regime**). To change this regime it is necessary to have set **SW lock OFF** according to the previous paragraph.
- h) *SW3 W mode* – switch of working regime of comparator-switch **3**. The key ▲ sets the state **ON** (**Window regime**), the key ▼ sets the state **OFF** (**Simple regime**). To change this regime it is necessary to have set **SW lock OFF** according to the previous paragraph f).
- i) *SW lock* – the same as for *Paragraph f)*. It locks the setting after a change of parameters in the *Paragraphs: g) or h)*
- j) List of communication parameters: RS232 baud rate, Modbus baud rate, Modbus address.
- k) Date of translation of firmware equipment.
- l) Return to measuring mode.

### **Warning**

When the **Service mode** is active most of the working functions including communication channels are out of proper operation. That is why it is recommended to enter the **Service mode** only when the pump is not connected or when a change of whatever parameters or states cannot threaten the operation of the supply or surrounding devices.



---

## 7. SERVICE MODE NP

The service mode gives some additional information and enables the change of some working parameters.

The service mode is accessible in **ON** or **OFF state** and can be initiated by simultaneous pressing of pushbuttons **A/V/W**, **Torr/Pa/mbar** and with slight delay **ON/OFF** in **NEG** section. The content of **Service mode** changes according to state **ON** or **OFF**. The following item of **Service mode** is achieved by repeated pressing of **MODE** pushbutton.

The **ON-state** will show on the display:

- a) Current NEG pump setting
- b) *AD (CD)* – value of digital to analog converter (DAC) for mode **Activation (Conditioning)**, magnitude of output voltage and magnitude of output current. The value of DAC can be altered by means of pushbutton ▲ or ▼, that influences the real magnitude of output voltage.
- c) *Low curr* – low current limit for automatic start after line restoration. This value can be altered by means of pushbutton ▲ or ▼.
- d) *High curr* – high current limit for automatic start after line restoration. This value can be altered by means of pushbuttons ▲ or ▼.
- e) Return to previous state.

The **OFF-state** will show on the display:

- a) Current NEG pump setting. The type of pump may be changed by means of pushbutton ▲ or ▼ to **NEXTorr D100-5** or **NEXTorr D200-5**.
- b) *Low curr* – low current limit for automatic start after line restoration. This value can be altered by means of pushbutton ▲ or ▼.
- c) *High curr* – high current limit for automatic start after line restoration. This value can be altered by means of pushbuttons ▲ or ▼.
- d) *Cable length* – length of used **NP** cable. The value can be altered by means of pushbuttons ▲ or ▼ in extent 1 to 20 m with step 0.1 m.

### **Warning**

When the **Service mode** is active most of the working functions including communication channels are out of proper operation. That is why it is recommended to enter the **Service mode** only when no pump is working or when a change of whatever parameter or state cannot threaten the operation of the supply or surrounding devices.

## 8. THE OUTPUT CONNECTOR FUNCTION

The output connectors serve for a possible connection of a device designed for monitoring or controlling the supply activity. The **IN/OUT** is intended for connection to protective hardware systems; the **RS232/RS485** connector can be utilized for communication purposes via the RS232 or RS485 interface.

### 8.1. IN/OUT Interface

Pin layout of the connector IN/OUT

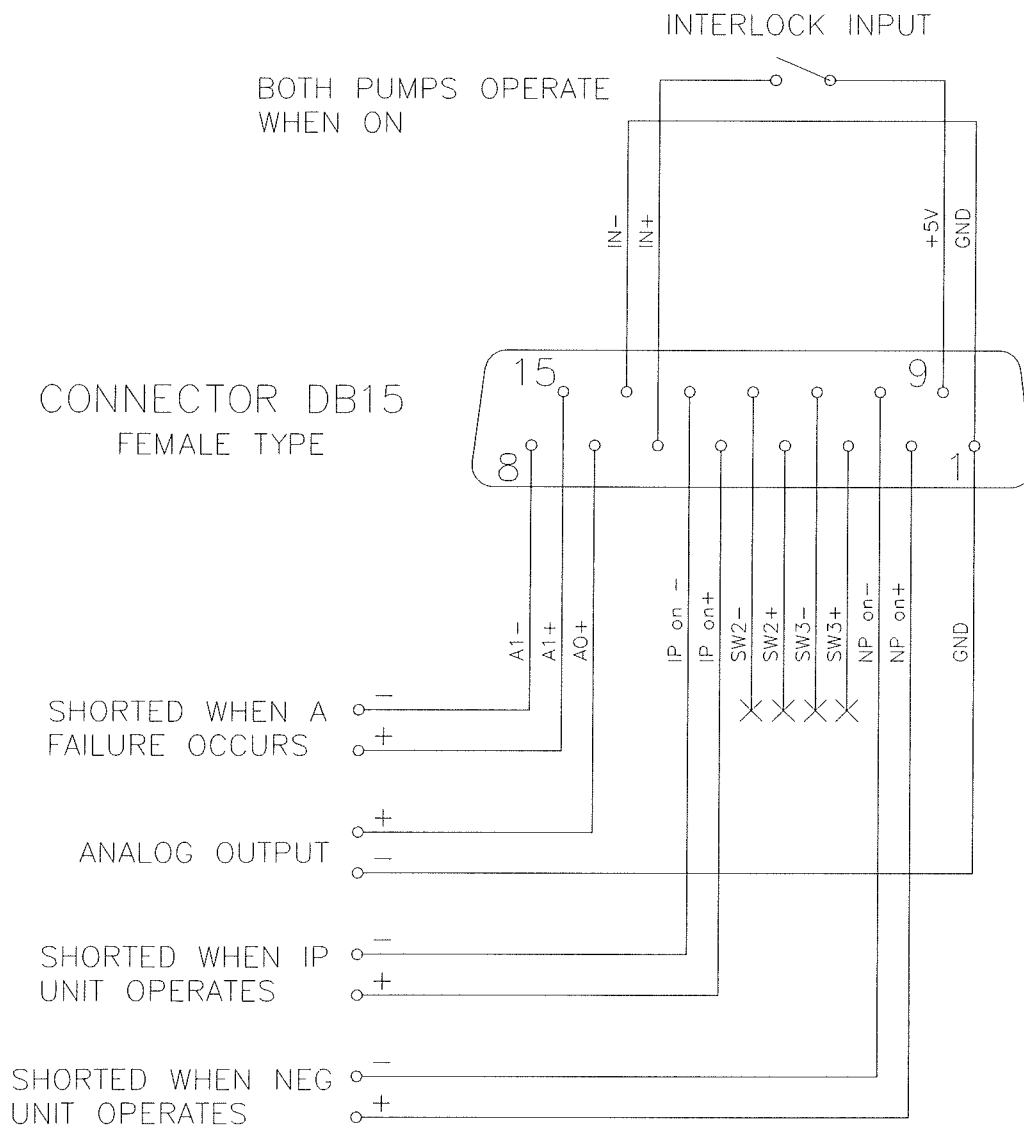

Pin	Meaning	
1	GND	output of negative feeding voltage
2	NP on+	positive terminal of switch Operation NP
3	SW3+	positive terminal of comparator switch 3
4	SW2+	positive terminal of comparator switch 2
5	IP on+	positive terminal of switch Operation IP
6	IN+	positive terminal of control input 1
7	AO	analog output
8	AI-	negative terminal of switch Alarm
9	+5V	output of positive feeding voltage
10	NP on-	negative terminal of switch Operation NP
11	SW3-	negative terminal of comparator switch 3
12	SW2-	negative terminal of comparator switch 2
13	IP on-	negative terminal of switch Operation IP
14	IN-	negative terminal of control input 1
15	AI+	positive terminal of switch Alarm

If one of the above events reaches such a value the appropriate comparator-switch is connected (see Sec. 4) and the impedance between the terminals + and – is between 11 and 15  $\Omega$ . The maximal current through the connected terminals must be limited up to 100 mA.

Maximal permissible voltage between switched off terminals + and – is 30 V.

The supply works only when the control input IN1 is active, that means, that a current from 2 to 10 mA through the terminals IN1+ and IN1– must flow (see Sec. 3). Input impedance of circuits IN is about 2 k $\Omega$ .

Above-mentioned polarity for all terminals SW and IN must be kept. All pairs of terminals SW and IN are galvanically insulated. The voltage between pairs must not exceed 100 V.

---

## 8.2. Analog Output

In the IN/OUT connectors is enclosed the ANALOG OUTPUT for the current/pressure signal (pin 1 and 7). This signal is proportional to logarithm of ion pump current. The limits of the signal are: 0 V for  $\leq 1$  nA; 10 V for 100 mA. Pressure scale, must be recalculated accordingly to ion pump sensitivity and chosen pressure unit.

### Analog Output (AO) voltage versus IP current.

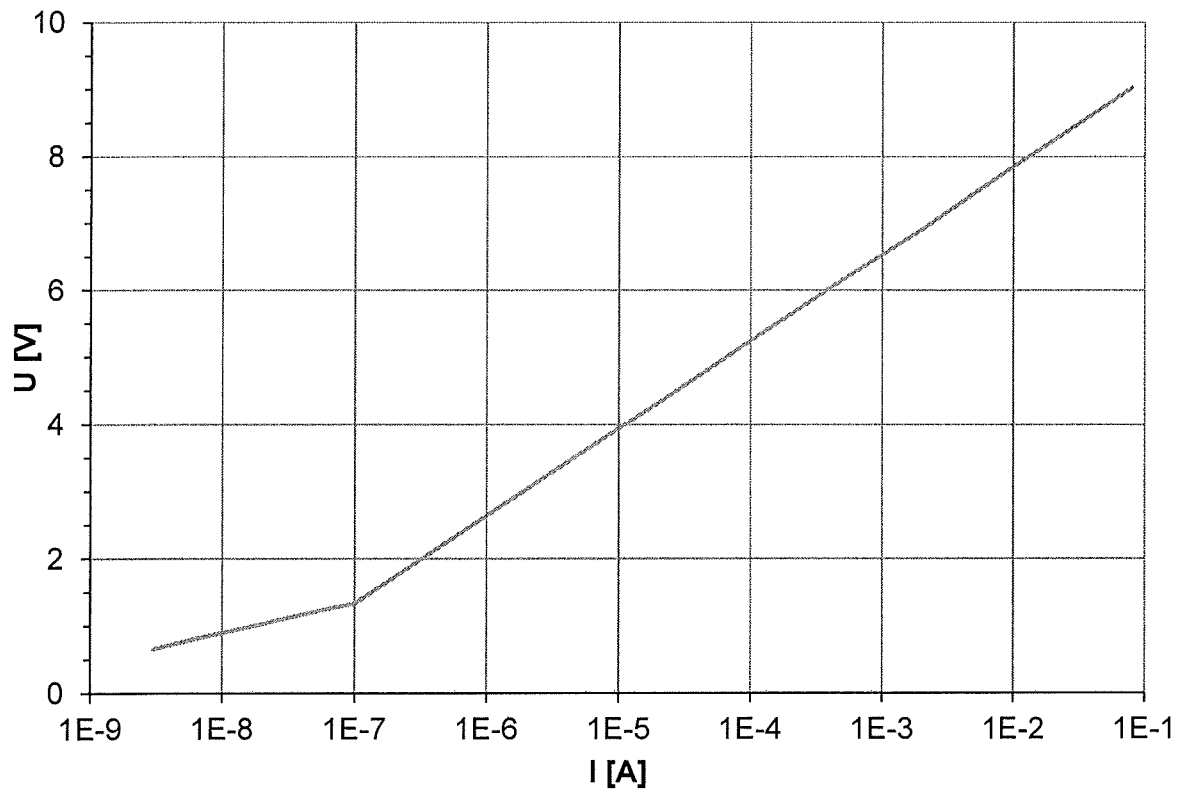

Voltage is referenced to GND pin; minimal load resistance is 100 k $\Omega$ .

### 8.3. RS232/485 Interface

Pin layout of the connector RS232/RS485

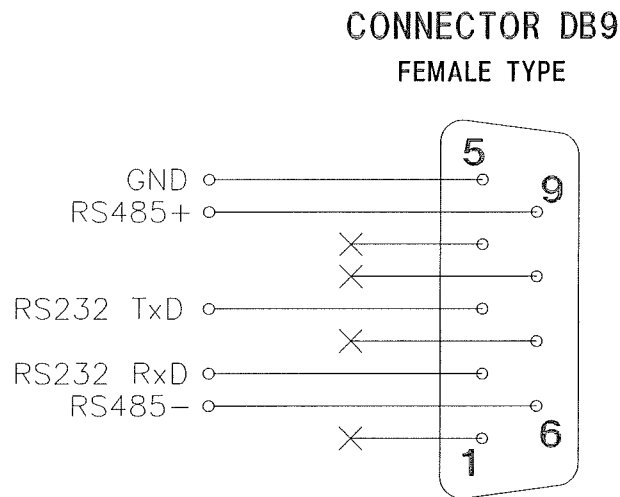

Pin	Meaning
2	RxD receiver RS232
3	TxD transmitter RS232
5	GND ground connection RS232
6	RS485- negative com. line
9	RS485+ positive com. line

Control of the supply by means of serial interfaces is described in following chapters.

---

## 9. CONTROL VIA A SERIAL CHANNEL

### 9.1. Definition

For communication, the RS232 standard serial interface is used in three-wire connection or two wire RS485 serial interface. For RS232 only signals TxD and RxD are used. Both communication channels are galvanically separated from the frame of the supply.

Default communication baud rate for RS485 is 19,200 Bd and for RS232 is 115,200 Bd, 8 data bits, 1 stop-bit, without parity bit, flow control none. To change the values see Sec. 6. With the PC use a Null Modem cable.

In the text below, the following symbols and abbreviations are used:

Symbol	Meaning
PC	computer PC/AT
NIOPS	ion and NEG pump supply NIOPS03
Transmission	communication from PC into NIOPS
Reception	communication from NIOPS into PC
[ ]	optional parameter in a command
<CR>	carriage return (ASCII 13)
<LF>	line feed (ASCII 10)
<ENQ>	communication poll (ASCII 5)
<ACK>	acknowledgement (ASCII 6)
<NAK>	negative acknowledgement (ASCII 21)

### 9.2. Communication protocol for RS232

All commands are sent in the form of ASCII sequences terminated with <CR>, [<LF>] characters. The character <LF> is optional. After every command transmitted from PC, an acknowledgement has to be waited for (<ACK>, <NAK>). Spaces inside the sequence are ignored.

### 9.3. The transmission protocol

PC →	← NIOPS	Meaning
Mnemonics, parameters <CR>[<LF>]		IPS receives the command with the termination
	<ACK><CR>	Reception acknowledgement

On request, NIOPS sends its operation parameters into the PC. Before the request is issued, the contents of the transmission have to be defined. The request is realized by transmitting of <ENQ> (for defined parameters). Repeated transmission of <ENQ>, the requested parameter is repeatedly transmitted. When no valid request precedes <ENQ>, a failure report is transmitted.

PC →	← NIOPS	Meaning
Mnemonics, parameters <CR>[<LF>]		NIOPS receives the command with the termination
	<ACK><CR>	Reception acknowledgement
<ENQ>		Data communication request
	Measured values or parameters <CR>	Data transmission with the termination
<ENQ>		Data communication request
	Measured values or parameters <CR>	Data transmission with the termination

### 9.4. Service of failures

PC →	← NIOPS	Meaning
Mnemonics, parameters <CR>[<LF>]		NIOPS receives the command with the termination
<i>Programmer error or communication failure</i>		
	<NAK><CR>	Negative acknowledgement of the receipt

---

## 9.5. The commands used

### The software version

Transmission: V<CR>[<LF>]  
Reception: NIOPSxy<CR>  
          x number of version  
          y date of translation  
Example: NEGH.3 Jun 04 2011<CR>

### The NIOPS status

Transmission: TS<CR>[<LF>]  
Reception: report <CR><LF>  
Example: IP ON, Switch 2 OFF, Switch 3 OFF, NP ON, Alarm OFF<CR>

### Output IP current

Transmission: I<CR>[<LF>]  
Reception: <ACK>  
Transmission: <ENQ>  
Reception: xxxx<CR>  
or  
Transmission: i<CR>[<LF>]  
Reception: xxxx<CR>  
Example: 4209<CR>

xxxx hexadecimal expression of a 16-bit number. Two highest bits rr specify the range, the following ones are current i:

rr	i	
	range	step
00	0–10 $\mu$ A	1 nA
01	10 $\mu$ A–1 mA	0,1 $\mu$ A
10	1 mA–100mA	10 $\mu$ A

(4209<sub>H</sub> = 0100 0010 0000 1001<sub>B</sub>, rr = 01, i = 1000001001<sub>B</sub> = 521<sub>D</sub>, i = 521 × 0,1  $\mu$ A = 52,1  $\mu$ A)

or

Transmission: TI<CR>[<LF>]  
Reception: report <CR>  
Example: Current 52.1 uA<CR>

### IP voltage

Transmission: U<CR>[<LF>]  
Reception: <ACK>  
Transmission: <ENQ>



---

Reception:        uuuu<CR>  
or  
Transmission:    u<CR>[<LF>]  
Reception:        uuuu<CR>  
                    uuuu is voltage in volts, hexadecimal expression  
Example:          1388<CR>  
                    (1388<sub>H</sub> = 5000<sub>D</sub>; 5000 V)

or

Transmission:    TU<CR>[<LF>]  
Reception:        report <CR>  
Example:          Voltage 5.00 kV<CR>

### IP pressure

Transmission:    Tx<CR>[<LF>]  
                    x    T    expression in Torr  
                              B    expression in mbar  
                              P    expression in Pa  
                              t    expression in Torr (only value)  
                              b    expression in mbar (only value)  
                              p    expression in Pa (only value)

Reception:        report <CR>

Example:          Transmission:    TT<CR>[<LF>]  
                              Reception:        Pressure 2.6E-07 Torr<CR>  
                              Transmission:    Tt<CR>[<LF>]  
                              Reception:        2.6E-07<CR>

### Switching the IP supply off

Transmission:    B<CR>[<LF>]  
Reception:        \$<CR>

### Switching the IP supply on

Transmission:    G<CR>[<LF>]  
Reception:        \$<CR>

This command switches on the supply, provided it is not prevented owing to overheating, low mains voltage, state of signal IN1 or a failure.

### Changing the NP type

Transmission:    Tx<CR> [ <LF> ]  
                    x    1    D100-5  
                              2    D200-5

Reception:        <CR>

---

### Setting the NEG cable length

Transmission: Lxxx<CR> [<LF>]  
                  xxx actual cable length [m] ×10  
Reception:     \$<CR>  
Example:        L045<CR> [<LF>] cable length is set to 4.5 m

### Switching the NP supply off

Transmission: BN<CR> [<LF>]  
Reception:     \$<CR>

### Switching the NP supply on

Transmission: GN<CR> [<LF>]  
Reception:     \$<CR>

This command switches on the supply, provided it is not prevented owing to overheating, low mains voltage, state of signal IN1 or a failure.

### Restart NEG pump parameters (after mains interruption)

Transmission: TE<CR> [<LF>]  
Reception:     NEG Low I: xxxx (Hex) <CR>  
                  NEG High I: yyyy (Hex) <CR>

Data are received in format xxxx (yyyy), where xxxx (yyyy) are 16-bit hexadecimal numbers. Two highest bits specify the range; the following ones are the current (see **Output IP current** on *Pag. 24*).

The command shows extent of IP current which enables after mains interruption an automatic start of previous NEG pump working parameters.

Example:        NEG Low I: 0032 (Hex) <CR>  
                  NEG High I: 2134 (Hex) <CR>  
                  i.e. NEG Low I = 50 nA  
                  NEG High I = 8.50 uA

### Setting NEG pump parameters (after mains interruption)

Transmission: Exxxxyyyy<CR> [<LF>]  
                  xxxx low IP current value in Hex format, see *Pag. 24*  
                  yyyy high IP current value in Hex format, see *Pag. 24*  
Reception:     \$<CR>

The command sets extent of IP current which enables after mains interruption an automatic start of previous NEG pump working parameters.

Example:        E00322134<CR> [<LF>]  
                  \$<CR>

---

### The change of NP mode

Transmission: Mx<CR>[<LF>]  
x     1     Activation  
          2     Timed Activation  
          3     Conditioning  
          4     Timed Conditioning

Reception:     \$<CR>

### Change of comparator mode

Transmission: Wx<CR> [ <LF> ]  
x     0     SW2 – simple, SW3 – simple  
          1     SW2 – window, SW3 – simple  
          2     SW2 – simple, SW3 – window  
          3     SW2 – window, SW3 – window

Reception:     \$<CR>

Example:       W1<CR> [ <LF> ]  
               \$<CR>

### IP current/pressure conversion constant

Transmission: TK<CR> [ <LF> ]  
Reception:     report <CR>  
Example:       Pump Constant 65 A/Torr<CR>

### Setting IP current/pressure conversion constant

Transmission: Kxxxx<CR> [ <LF> ]  
               xxxx value of conversion constant [A/Torr](decimal)

Reception:     \$<CR>

Example:       K0065<CR> [ <LF> ]  
               \$<CR>

### The IP current comparators setting

Transmission: Pn[xxxx]<CR>[<LF>]  
n     1     level 1H  
          2     level 2L  
          3     level 2H  
          4     level 3L  
          5     level 3H

               xxxx has the same signification as for the current reading

Reception:     \$<CR>

               If the value xxxx is not transmitted the received answer is topical hexadecimal value of the comparator.

---

---

### Output IP voltage adjustment

Transmission: U[xxxx]<CR>[<LF>]  
xxxx has the same signification as for the voltage reading

Reception: \$<CR>

Resulting voltage is automatically limited to the extend 1.2 to 6 kV.

### Output IP power

Transmission: TW<CR>[<LF>]

Reception: report<CR>

Example: Power 402 mW<CR>

### Worked out time

Transmission: TM<CR>[<LF>]

Reception: report<CR>

Example: Working time IP 12 Hours 47 Minutes  
Working time NP 10 Hours 40 Minutes<CR>

### Temperature of IP and NP generator

Transmission: TC<CR>[<LF>]

Reception: report<CR>

Example: Temperature 32 C, 37 C<CR>

### Status of IP comparators

Transmission: TLyz<CR>[<LF>]

y – form of output: I – displayed in current units  
T – displayed in Torr  
B – displayed in mbar  
P – displayed in Pa

z – number of comparator 1–3

Reception: report<CR>

Example: Transmission: TLI2<CR>[<LF>]

Reception:  
Switch 2 L: Current 854 uA<CR>  
Switch 2 H: Current 1.06 mA<CR>  
Window mode ON Switches locked<CR>

or

Transmission: TLB2<CR>[<LF>]

Reception:  
Switch 2 L: Pressure 3.7E-06 mbar<CR>  
Switch 2 H: Pressure 4.5E-06 mbar<CR>  
Window mode ON Switches locked<CR>

### Settings of commutation interfaces

Transmission: Rxy[y]<CR>[<LF>]

---

---

x = 0 / 1: RS232 / Modbus baud rate:  
y = 1: 4,800 Bd  
y = 2: 9,600 Bd  
y = 3: 19,200 Bd  
y = 4: 38,400 Bd  
y = 5: 57,600 Bd  
y = 6: 115,200 Bd  
y = 7: 230,400 Bd  
x = 2: yy – Modbus address (hexadecimal)

Reception: report<CR>  
Example: Transmission: R16<CR>[<LF>]  
Reception: New Modbus Baud rate: 115200<CR>

#### Status of communication interfaces

Transmission: TR<CR>[<LF>]  
Reception: report<CR>  
Example: Baud rate for RS 232 is 115200  
Baud rate for Modbus is 19200  
Address for Modbus is 100<CR>

After commands I, i, U, u, TI, TU, TW, TT, TP, TB, Tt, Tp, Tb, TS it is possible to use transmission of <ENQ> for repeated reading of desiderative value.

## 9.6. Communication protocol for RS485 MODBUS RTU

The RS485 serial interface supports MODBUS RTU protocol; however, not all parts of the protocol have been implemented. There is function "Reading Holding Registers" (code 03h) only available. This function is used to read the contents of a block of holding 2-bytes registers. The request frame specifies the starting register physical address and the number of registers to be read. The data from register in the response frame are packed as two bytes (word), with binary content right justified within each byte. The byte order inside the single word is MSW and then LSB.

Default communication baud rate is 19,200 Bd, no parity, MODBUS address is 100.

### Modbus Holding Register Table (function code 03)

Register address	Physical address	Format	Access	Variable name	Comment
400001	0000h	UINT16	R	Unit address	1–247 valid range
400002	0001h	UINT16	R/W	Param1adr	Choice parameters register ****
400003	0002h	UINT16	R/W	Statusregadr	NP status register: 0000h = off 0100h = on 0x80h = short 0x81h = open 0x82h = overheating 0x83h = low supply voltage 0x84h = interlock off
400004	0003h	UINT16	R	RuntimeadrLo	Elapsed time – LSW (seconds)
400005	0004h	UINT16	R	RuntimeadrHi	Elapsed time – MSW [seconds]
400006	0005h	UINT16	R	Poweradr	NP power value [W]
400007	0006h	UINT16	R/W	Opmodeadr	Mode register: 0000h = idle 0001h = activation mode 0002h = timed activation mode 0003h = conditioning mode 0004h = timed conditioning mode
400008	0007h	UINT16	R/W	Errnoadr	Error occurrence counter: 1–6 valid range write 0 = rezero
400009	0008h	UINT16	R	ErrtimeLoadr	Error time – LSW
400010	0009h	UINT16	R	ErrtimeHiadr	Error time – MSW
400011	000Ah	UINT16	R	Errmodcodadr	Error code of occurred error: 0080h = short 0081h = open 0082h = overheating 0083h = low supply voltage 0084h = interlock off
400012	000Bh	UINT16	R	Tempadr	NP generator temperature [°C]
400013	000Ch	UINT16	R/W	Commparamadr	RS232 baud rate, Modbus baud rate, Modbus address **
400014	000Dh	UINT16	R/W	IPCadr	IP constant – conversion current/pressure A/Torr value × 10
400015	000Eh	UINT16	R/W	Compstatadr	SW2/3 W mode settings 0000h = SW2 – simple,

Register address	Physical address	Format	Access	Variable name	Comment
					SW3 – simple. 0001h = SW2 – window, SW3 – simple. 0002h = SW2 – simple, SW3 – window. 0003h = SW2- window, SW3– window
400016	000Fh	UINT16		Param2adr	Setting parameters register ****
400017	0010h	UINT16	R	Ipcurradr	IP current *
400018	0011h	UINT16	R/W	Ipvoltadr	IP voltage – valid range: 1.200–6.000 V
400019	0012h	UINT16	R/W	Ipstatadr	IP status register: 0000h = off 0100h = on LSW = 0000 0xxx : sw 1 off LSW = 0000 1xxx : sw 1 on LSW = 0000 x0xx : sw 2 off LSW = 0000 x1xx : sw 2 on LSW = 0000 xx0x : sw 3 off LSW = 0000 xx1x : sw 3 on
400021	0014h	UINT16	R/W	IPsw1adr	IP current limit level sw 1 HI *
400022	0015h	UINT16	R/W	IPsw2adr	IP current limit level sw 2 LO *
400023	0016h	UINT16	R/W	IPsw3adr	IP current limit level sw 2 HI *
400024	0017h	UINT16	R/W	IPsw4adr	IP current limit level sw 3 LO *
400025	0018h	UINT16	R/W	IPsw5adr	IP current limit level sw 3 HI *
400026	0019h	UINT16	R	IPtempadr	IP generator temperature [°C]
400027	001Ah	UINT16	R/W	Ntypeadr	NEG pump type@cable length ***
400028	001Bh	UINT16	R/W	NLCadr	NEG Low Current * restart condition after mains drop
400029	001Ch	UINT16	R/W	NHCadr	NEG High Current * restart condition after mains drop

Note:

- \* Data in format xxxx, where xxxx is 16-bit hexadecimal number. Two highest bits specify the range; the following ones are the current (see Output IP current on page 24).
- \*\* Data in format xyuv, where:
  - x corresponds to RS232 baud rate (see page 28 Settings of commutation interfaces, y coding),
  - y corresponds to Modbus baud rate (see page 28 Settings of commutation interfaces, y coding),
  - uv corresponds to Modbus address (hexadecimal).
- \*\*\* Data in format xyuv, where:
  - xy 01h (D100-5),

---

02h (D200-5),  
uv (cable length [m] × 10) h.

\*\*\*\* Value at address 2 – content selector of address 16:

- 0 DAC value of CON of the pump D100,
- 1 DAC value of CON of the pump D200,
- 2 DAC value of ACT of the pump D100,
- 3 DAC value of ACT of the pump D200;

Value at address 16 – basic value of DAC for chosen mode and pump.

To preserve this setting use following sequence:

- write value of 255 at address 2,
- write any value at address 16.

**Note:**

The values of DAC shown in service mode differ from those ones set (see previous paragraph). The service mode values comprise compensation for cable length.

**Data format representation**

<b>Format</b>	<b>Description</b>	<b>Bits</b>	<b>Range</b>
UINT16	Unsigned integer	16	0–65.535



---

## 10. MAINTENANCE AND TROUBLESHOOTING

The supply needs minimum maintenance. Depending on the dust levels in the environment where the device is being operated, a periodic check of the vents on upper and lower side of the device and outlet of the fan is desirable. In case of dust contamination it can be cleaned by means of a vacuum cleaner.

The only repair left to the user is the replacement of the mains fuse on the rear panel in the mains plug body. It is easy to recognize when a fuse has burnt out because after the mains switch **LINE** is pushed to the position I, neither it nor the display lights. If the fuse burns out even after having been substituted several times, some more serious failure is involved and the supply should be shipped for repair.

### List of warnings:

- **Wait** - The initialization process is active after the mains switch was switched on.
- **Disabled** - The supply is disabled by wrong connection of interlock input IN see Sec. 3 and 8.
- **Act is running** - NP is running. The action requires the switching off of the NEG pump
- **Switch OFF IP** - IP is running. The action requires the switching off of the ION pump.

### 10.1. NP troubleshooting

Whenever during a running mode a failure in NEG pump or supply unit appears the running mode is interrupted (output voltage is set to zero) and type of failure is shown on display:

- **Open!** - interrupted heating circuit of NEG pump or disconnected cable;
- **Short!** - short circuit of heating element of NEG pump to frame or shorted leads of heating element;
- **High Temp** - the temperature inside unit has overcome 65 °C;
- **Low Voltage** - low mains voltage for chosen working mode;

At the same time the yellow indicator starts to blink, a number of failure counts is lighted on and alarm sound is generated. The indicator blinking and sound will last until the reason of failure report is removed. As soon as the NP supply unit is repaired, the previous operational mode is displayed and the supply unit can be started again.

When the supply is in **STOP state** it is possible to show details of any failure from recorded list (up to 6) by simultaneous pressing of pushbuttons **A/V/W**, **Torr/Pa/mbar** and with slight delay **MODE** in **NEG** section. The latest failure is shown as the first and pressing pushbutton **MODE** repeatedly it goes successively to the first one and leaves the list at last. Displayed failure is marked by number at the end of display line. The display shows an abbreviation of working mode, type of failure and time when the failure occurred. When the number of failures is more than 6, the list is shifted so that the latest event would be recorded and the oldest one is lost. To clean the failure list, in list display, it is necessary to press the pushbutton **ON/OFF** in **NEG** section longer time until the count of failures disappears.

### List of failure abbreviations shown on display:

- **Opn** - stands for Open,
- **Sht** - stands for Short,

- 
- **LoV** - stands for Low Voltage,
  - **HiT** - stands for High Temp.

**List of setting errors shown on display:**

- **Overload! Check setting** - the power to NEG pump exceeded the allowed limit. Check correct setting of NEG pump type, length of used cable and final value of AD (see *SERVICE MODE NP*). If the previously mentioned items are correct then the resistance of heating element might be too small.
- **Check setting** - the power to NEG pump is smaller than necessary limit. Check correct setting of NEG pump type, length of used cable and final value of AD (see *SERVICE MODE NP*).

## 10.2. IP troubleshooting

During a running mode of the ION pump may be displayed these messages:

- **Arcing** - The message with accompanying sound signal will appear after automatic switching off of the power supply due to either an unstable electric arc in ion element or an arc of high voltage in the circuit of ion element cable. In this situation, the power supply will try to switch on and if the third attempt is not successful, the supply remains permanently switched off with error report and sound signal. The remedy is to forepump to higher vacuum or to remove the reason of arcing. It is possible to switch on the supply unit again by pushing the **ON/OFF** pushbutton.
- **Overload** - The supply stayed switched off after previous unsuccessful attempts at an automatic start. The pump current apparently went over the value of the comparator **1H**. The switching off is signaled by an acoustic sound as well. Start of the supply can be made by pressing the **ON/OFF** pushbutton.
- **Switch locked** - This report can appear after pressing the pushbutton or when trying to change some of any adjustable values. If a new adjustment is needed it is necessary to unlock the switches first (see Sec. 6).
- **High Temp** - The supply is switched off as a consequence of overheating the generator HV. This circumstance can occur at high ambient temperature and simultaneously maximal output power of the supply. The switching off is signaled by an acoustic sound as well. After decrease of inner temperature the supply will start automatically again. If the failure lasts too long time or it appears too often the reason for it might be:
  - Excessive high ambient temperature. Reduce the ambient temperature or load of the supply.
  - A failure of the supply fan. Ensure a repair. (The fan runs if the temperature increases over 45 °C and stops if the temperature decreases below 40 °C – see Sec. 6).
  - An insufficient flow of cooling air through vents. Ensure a sufficient air flow, leave the supply switch on. After being cooled by its fan the supply will start.
- **Low Voltage** - The supply is switched off as a consequence of low mains voltage (under low margin of working extent) apparently at high output power. The switching off is signaled by an acoustic sound as well. As long as this state remains it is probable that the failure message and operating regime will change periodically until sufficient mains voltage is ensured.
- **Starting** - It indicates an attempt to start HV generator, which does not work for other reasons than overcurrent stop.
- **Error** - It indicates switching off the generator HV when the load current, of 90 mA, was exceeded repeatedly (possible short circuit in the HV cable, in the pump or bad forevacuum). The switching off is signaled by an acoustic sound as well. Disconnecting the HV cable from the

---

supply, and switch on the IP, if the failure message continues there is a supply failure and the device must be shipped for repair (see Sec. 15).

- **Internal Error** - It indicates an error in internal communication of the unit. If the failure message continues after the switch off/on of the instrument there is a supply failure and the device must be shipped for repair (see Sec. 15).
- \* (*asterisk*) - The asterisk shows up when the IP current reaches 0 nA. This means the pressure inside the IP is so low that the current is below detection limit.

 **Warning**

In the case the HV cable is disconnected, the current will be 0 and the asterisk will show up as well.

---

## 11. SPECIFICATIONS

### IP Section

Nominal output voltage		5 kV±2 %
Range of adjustment		1.2÷6 kV
Output voltage polarity		positive
Output voltage ripple (informatively)	at $I_{out} = 0.5 \text{ mA}$ at $I_{out} = 5 \text{ mA}$	approx. 1 $V_{p-p} / 20 \text{ kHz}$ approx. 10 $V_{p-p} / 20 \text{ kHz}$
Maximum output current		89.9 mA
Obtainable output power		25–30 W

### NP Section NEX Torr D100-5

Nominal output voltage	Activation and Timed Activation mode	9 V±2 %
	Conditioning and Timed Conditioning mode (voltage for both modes is adjustable)	4.5 V
Output power for Activation and Timed Activation mode	45 W	

### NP Section NEX Torr D200-5

Nominal output voltage	Activation and Timed Activation mode	12.5 V±2 %
	Conditioning and Timed Conditioning mode (voltage for both modes is adjustable)	6.2 V
Output power for Activation and Timed Activation mode	60 W	

### Complete unit

#### Outputs

5× current comparators-switches*	on: $Z = 13 \pm 2 \ \Omega$
positive feeding voltage	+5 V / 20 mA
negative terminal	GND
* <i>max. voltage between switched off terminals</i>	30 V
<i>max. current through connected terminals</i>	100 mA

#### Inputs

enable input		2–10 mA / 2 k $\Omega$
Communication interface	RS232	4,800–230,400 Bd
	RS485	4,800–230,400 Bd
Mains voltage		90÷260 V / 48÷63 Hz
Maximal consumption		230 VA
Fusing		T2A
Weight		3.2 kg
Ambient temperature at operation		5÷40 °C
Relative humidity		20÷80 %

The device is an instrument of safety class I and fully complies with the requirements for electrical equipments of the Directive 2006/95/EC for measure, control and laboratory use.

---

## **12. INSTRUCTION FOR INSTRUMENT DISPOSAL**

The instrument disposal should be carried out in compliance with the user's country applicable regulations.

The instrument contains materials which may endanger the environment. When disposing of the instrument, separate disassembly by material is to be arranged for and the different materials shall be collected separately for disposal. Neither the collection nor the transport of thus collected and separated materials is subject to any special requirements.

---

### 13. PRODUCT CONFIGURATIONS AND ACCESSORIES

Configurations and accessories are given in the following section:

<u>Product description</u>	<u>Code</u>	<u>Note</u>
- NEXTorr Power Supply NIOPS-03	3B0408	Power supply for NEXTorr Getter Pumps
- NIOPS-03 KIT OF CABLES-03 (3 pcs)	3B0409	ION, NEG pumps and main cables (standard)
- NIOPS-03 OUTPUT CABLE ION 3mt	3B0410	ION Pump cable 3 m length (standard)
- NIOPS-03 OUTPUT CABLE NEG 3mt	3B0411	NEG Pump cable 3 m length (standard)
- NIOPS INPUT CABLE	3B0398	European plug Schuko P660
- RS485/232 CONVERTER	3B0379	To operate the power supply via RS485/232

---

## 14. WARRANTY CONDITIONS

SAES guarantees that the Products delivered shall be free from operational and material defects and shall comply with the construction and functional data and specifications indicated in the Contractual Documents.

This warranty shall have a term of TWELVE (12) MONTHS. For Products which require installation at BUYER's facility by SAES personnel, the warranty shall have a term of TWELVE (12) MONTHS from the date of installation or FOURTEEN (14) MONTHS from the date of delivery, whichever term is shorter. Subject to the remainder of this Article 14, any action by BUYER for any alleged breach of this warranty shall be brought in writing by BUYER within thirty (30) days of BUYER's discovery of the breach. This warranty shall only apply to the BUYER and may not be assigned.

During the term of the warranty set forth above, SAES will promptly repair the Products which for their features can be repaired and which do not conform to the specifications and which BUYER returns to SAES at the address provided. Unless otherwise agreed and specified, BUYER shall be responsible for all transportation charges incurred in returning Products to SAES for repair; BUYER shall have obtained a Returned Material Authorization ("RMA") number and specific shipping instructions from SAES prior to its shipping of the Products to SAES. SAES shall not unreasonably deny BUYER authorization to ship Products to SAES. SAES shall return repaired Products to BUYER, with transportation charges prepaid by SAES, unless otherwise agreed. Additional information is available on the General conditions of sales.

---

## 15. SERVICE

In case of a failure, please check if the fuse located on the supply rear panel has not blown. If the failure persists after the fuse has been replaced, inform the manufacturer who will repair the supply.

For a request of return of the instrument please contact SAES Customer Service:

### 15.1. Sales & Service Locations:

Europe, Middle East and Africa:

**SAES Getters S.p.A.**

Viale Italia 77

20020 Lainate (Milan) – Italy

Ph. +39 02 93178 1 - Fax +39 02 93178 320

**European Customer Relations:**

Ph. +39 02 9317 8402 - Fax +39 02 93178320

E-mail: CRM\_SALES@saes-group.com

Asia and Oceania:

**SAES Getters S.p.A. - Japan Technical Service**

**Branch Office**

2nd Gotanda Fujikoshi Bldg.

23-1 Higashi Gotanda 5-Chome

Tokyo 141, Japan

Ph. +81 3 542 00431 - Fax +81 3 542 00438

**SAES Getters (Nanjing) Co.,Ltd.**

56 Xingangdadao, Xinchengwei

Nanjing Economic & Technical Development Zone

Nanjing 210038, Jiangsu Province, P.R. of China

Ph. +86 25 8580 2335 - Fax +86 25 8580 1639

**SAES Getters Korea Corporation**

7th Fl. Dongwon Bldg. 143-28

Samsung-dong, Gangnam-gu

Seoul 135-877, Korea

Ph. +82 2 3404 2400 - Fax +82 2 3452 4510/11

**SAES Getters S.p.A. - Taiwan Branch Office**

6F-1, No. 1071, Zhongzheng Road,

Taoyuan City, Taoyuan County 330

Taiwan, R.O.C.

Fax +886 3 346 8290

North and South America:

**SAES Getters USA, Inc.**

1122 East Cheyenne Mountain Blvd.

Colorado Springs, CO 80906 – USA

Ph. +1 719 576 3200 - Fax +1 719 576 5025



---

Remember that SAES cannot accept any instrument which contains biological or chemical hazards or radioactive substances. Please clearly inform SAES Customer Service should this have happened during pump use, so to discuss adequate solutions.



**SAES ADVANCED TECHNOLOGIES S.p.A. – Italy**  
**[www.saesgetters.com](http://www.saesgetters.com)**

This document is property of SAES Advanced Technologies S.p.A  
The information contained herein is subject to change without notice