

**Description of Experiment**

# **Vibrometer Education Kit**

## **PDV-100**

**Tutorial**

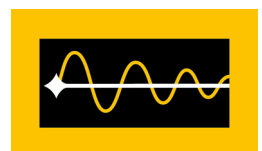

## Trademarks

Any trademarks or product names mentioned in this manual could be trademarks or registered trademarks belonging to their respective company or organization.



# Contents

<b>1</b>	<b>General Safety Information</b>	<b>1-1</b>
<b>2</b>	<b>Introduction</b>	<b>2-1</b>
<b>3</b>	<b>Experiment Euler's Disk</b>	<b>3-1</b>
3.1	Basics.....	3-1
3.1.1	Modeling the Euler's Disk.....	3-1
3.1.2	Metrological Acquisition of the Vibration.....	3-2
3.2	Experimental Setup.....	3-3
3.3	Carrying Out the Experiment.....	3-7
3.3.1	Parameter Settings on the Vibrometer.....	3-7
3.3.2	Vibration Measurement in the Time Domain.....	3-8
3.3.3	Vibration Measurement in the Frequency Range.....	3-15
3.3.4	Relationship between Vibration Amplitude and Vibration Frequency.....	3-18
3.3.5	Effect of Window Function on the FFT Spectrum.....	3-25
3.3.6	Effect of the Precessional Motion of the Euler's Disk on the Measurement Signal ...	3-26
3.3.7	The Vibration's Dependency on the Surface underneath the Test Base Plate.....	3-32
<b>4</b>	<b>Experiment Loudspeaker Characterization</b>	<b>4-1</b>
4.1	Basics and Experiment Preparation.....	4-1
4.2	Experimental Setup.....	4-2
4.3	Carrying Out the Experiment.....	4-5
4.3.1	Measuring the Loudspeaker Frequency Response.....	4-5
4.3.2	Examining the Deflection Shapes of the Loudspeaker.....	4-13
4.3.3	Examining the Linearity of the Loudspeaker.....	4-16
<b>5</b>	<b>Demonstration Experiment Optical Microphone</b>	<b>5-1</b>
5.1	Basics.....	5-1
5.2	Experimental Setup.....	5-1
5.3	Carrying Out the Experiment.....	5-2
<b>6</b>	<b>Literature Recommendations</b>	<b>6-1</b>

## Contents

# 1 General Safety Information



---

**WARNING!**

**Danger from laser light !** The PDV-100 Laser Doppler Vibrometer is fitted with a helium neon laser as its light source and is classified in Laser Class 2. Before switching on the instrument and while operating the instrument, please take the safety precautions as described in the manual for the PDV-100 Laser Doppler Vibrometer.

---



---

**WARNING!**

**Danger from a high level of sound intensity !** The test material allows headphones to be connected to the BNC signal output on the PDV-100 Laser Doppler Vibrometer. To avoid causing damage to hearing, make sure that the volume regulator integrated into the headphone cable is set to minimum volume. Only headphones that have been approved by Polytec may be connected to the PDV-100.

---

## 1 General Safety Information

## 2 Introduction

Since time immemorial, a gyrating disk has always been a fascinating, albeit well-known phenomenon. The most obvious example of this is the movement of a spinning coin. As the initially large gyrating movement levels off over time, this is associated with a continuous increase in the frequency. The movement ends with an abrupt landing and the coin stops. The experiment described in CHAPTER 3 examines the movement of a real disk, in the following called Euler's disk, with the aid of the measurement method Laser Doppler Vibrometry. The non-contact measurement principle allows continual acquisition of vibration of the Euler's disk without causing any reaction in the object so that the movement observed is pure and not affected by external influences. Examining a vibrating loudspeaker membrane is suggested as a basic experiment in CHAPTER 4. The familiarity of the object under investigation allows the experiment participants a clean entry into the world of non-contact vibration measurement technology. In conclusion, CHAPTER 5 describes the application of a Laser Doppler vibrometer as an optical microphone.

The experiments described can be used to support technical instruction at universities and colleges. All the experiments performed can be used both for presentation in lectures and seminars and also in practical sessions accompanying lectures. The present description is intended to be used as a basis for and to stimulate the development of practical training tailored to meet the requirements of the respective teaching content. The experiment description provides an overview of phenomena that can be observed on subjects of experiments and describes how to capture these metrologically in a step-by-step guideline. In addition to that, questions are formulated that can be used to prepare individual stages of the experiment.

For all experiments, there is the option of selecting whether to place emphasis on the subject of the experiment, or on the vibration measurement technology. Thus it is plausible to use the Vibrometer Education Kit in both the areas engineering mechanics, physics and metrology as well as signal processing. At the same time, multidisciplinary practical training on the basis presented here would make sense.

**Subject areas**

The following subject areas can be demonstrated using the experiments:

- Metrology: Theory and practical aspects of vibration measurement, operating principles of Laser Doppler Vibrometry
- Engineering mechanics: Movement of an ideal gyrating disk, movement of a real gyrating disk
- Signal processing: Sampling conditions, Fast Fourier Analysis (FFT)

To prepare the contents for the experiments, there is a list of literature recommendations in CHAPTER 6 for the individual technical subject areas. You will find further resources for experiment preparation, such as basics of Laser Doppler Vibrometry and a list with publications on the mechanics of the Euler's disk at [www.MyPolytec.net](http://www.MyPolytec.net). There are the following access options available:

a) Log in as experiment manager

Use the Login data that you received with the product documentation. If you do not have any Login data available, send us an E-mail to [info@polytec.de](mailto:info@polytec.de) stating your name, university/educational institution, E-mail address and serial number of the PDV-100.

Relevant information is made available to experiment managers on this page. Do not pass this Login data on to the experiment participants.

b) Login as student

Login: Student

Password: Student

On this page, information for experiment participants are available. The Login data can be passed directly on to experiment participants.

We wish you an exciting introduction into the world of vibrations.



### 3 Experiment Euler's Disk

#### 3.1 Basics

##### 3.1.1 Modeling the Euler's Disk

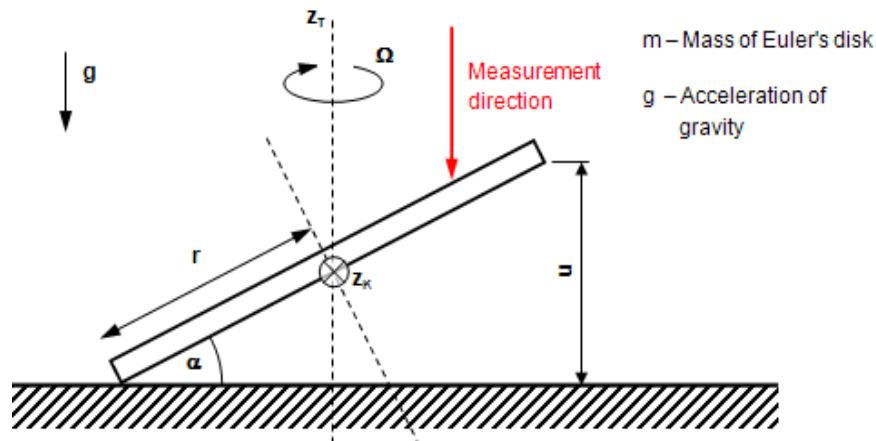

Figure 3.1: Model of the gyrating Euler's disk

The model used here as a basis for the Euler's disk is based on the equations for a rigid, thin disk (refer to FIGURE 3.1). The angular velocity of the gyrating movement  $\Omega$  is given by:

$$\Omega^2 = \frac{4g}{r \bullet \sin(\alpha)} \quad (\text{with } \Omega = 2\pi f) \quad \text{Equation 3.1}$$

$$\Omega^2 = \frac{4g}{r \bullet \alpha} \quad (\text{for } \alpha \ll 1). \quad \text{Equation 3.2}$$

The gyrating movement occurs by rotating the disk on its edge, whereby the center of mass is assumed to be stationary. According to equation (3.1), the disk gyrates with a constant frequency as long as no energy loss occurs in the system. Exactly the same as with an ideal pendulum (vibrating mass point), the gyration vibration of the disk is independent of its mass.

The energy of the gyrating disk, made up of the sum of potential and kinetic energy, is given by:

$$E = \frac{3}{2}mgr \bullet \sin(\alpha) \quad \text{Equation 3.3}$$

$$E = \frac{3}{2}mgr \bullet \alpha \quad (\text{for } \alpha \ll 1). \quad \text{Equation 3.4}$$

Equation (3.4) makes it obvious that when energy is lost, the tilt angle  $\alpha$  is reduced. In accordance with equation (3.2), this leads to an increase in the angular velocity  $\Omega$  of the gyrating movement.

From observing the extreme values, it can be said that:

$$\alpha \rightarrow 0; \alpha \rightarrow \infty.$$

As the tilt angle  $\alpha$  approaches 0, the angular velocity increases towards infinity and thus represents a singularity in finite time. In the experiment you can clearly observe the increase of the angular velocity as the gyrating movement flattens off. After a dramatic increase in the gyration frequency however, the Euler's disk abruptly comes to a standstill. The cause of this is the failure of the equations (3.1) and (3.3) for reasons that are the subject of scientific discussions. The main mechanisms of the energy dissipation are also hotly debated. In expert articles, viscous attenuation of the cushion of air in the wedge of air between the disk and the base, slippage between the disk and the base and also rolling friction are suggested<sup>1</sup>.

#### 3.1.2 Metrological Acquisition of the Vibration

In FIGURE 3.1, metrological acquisition of the movement of the disk is shown with a red arrow. The laser vibrometer measures the axial vibration of the disk using a fixed point parallel to the axis of gyration  $z_T$  of the Euler's disk. As can easily be seen, with an ideal gyration movement (i.e. a stationary gyration axis  $z_T$ ), the gyration frequency and the meteorologically acquired axial vibration frequency concur. The metrologically acquired amplitude of the vibration in contrast depends on the measurement point on the Euler's disk, that is precisely on the distance of the measurement point from the center axis of the Euler's disk.

For a basic understanding of the metrological situation, at this point we would like to draw your attention to the fact that the PDV-100 Laser Doppler Vibrometer measures and evaluates vibrational velocities. If the vibration displacement or acceleration are of interest in a measurement, then the velocity signals measured can be integrated or respectively differentiated using the VibSoft-20 software.

---

<sup>1</sup>. In a paper from the year 2000 in the magazine Nature, H.K. Moffat suggests that the viscous attenuation of the cushion of air is the primary dissipation mechanism. This assumption led to an intense discussion among experts and renewed interest in the phenomenon of the gyrating disk. Various authors cite the path of motion of the Euler's disk in a vacuum and the gyrating movement of a ring as arguments which rule out the viscous friction of the wedge of air between the Euler's disk and the base as the main mechanism for energy dissipation.

### 3.2 Experimental Setup

The experiment is set up on a stable, flat and level test bench as shown in FIGURE 3.2. When selecting the test bench, make sure that the central column of the tripod can be pushed right up close to the edge of the bench so that the tripod feet are slightly under the bench top. Direct mechanical contact with the bench should, however, be avoided as otherwise mechanical feedback from the gyrating disk can be felt by the vibrometer via the bench.

#### Mechanical setup

For the mechanical setup, please proceed as follows:

1. Lay the test base plate **2** on the test bench in such a way that the center of the test base plate is accessible from directly above by the laser beam of the Laser Doppler Vibrometer **4**. Place the Euler's disk **1** in the middle of the test base plate **2**.

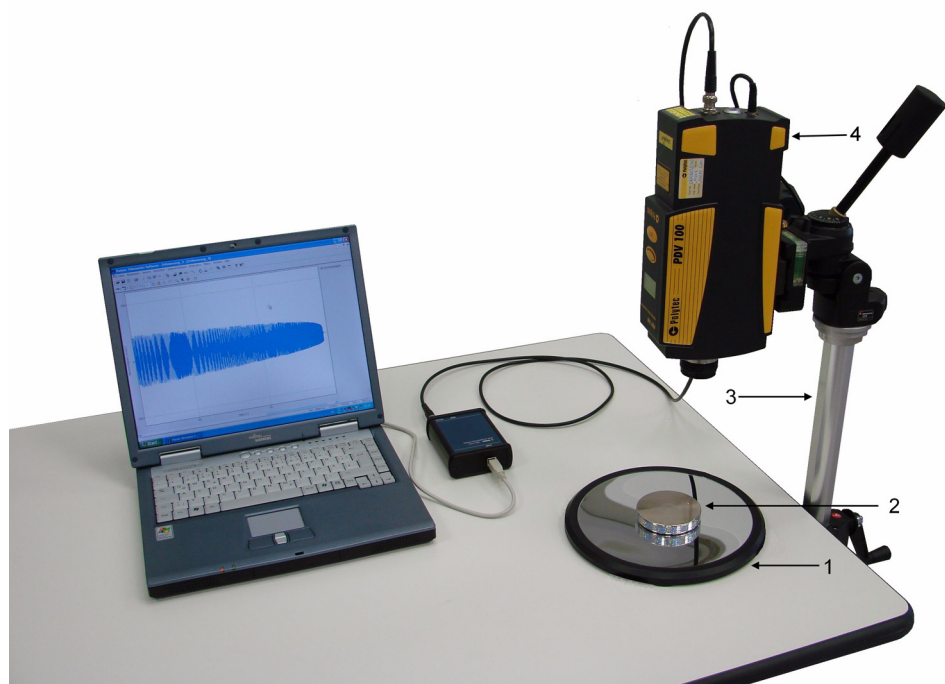

Figure 3.2: Experimental setup

2. Set up the tripod **3** next to the test bench in such a way that the central column of the tripod can be pushed up to the edge of the bench top.
3. To attach the vibrometer **4** to the tripod **3**, screw the tripod adapter plate (not shown) to the vibrometer (threaded hole 1/4"-20UNC). The adapter plate can now be fixed in place on the tripod head using the quick release mechanism.
4. Set the vibrometer up so that the lens **4** is pointing approximately straight down.



---

**WARNING!**

**Danger from laser light!** Connecting the mains supply to the PDV-100 switches the laser on. The laser in the PDV-100 belongs to Laser Class 2 and is therefore safe for the user as a general rule. Despite this, looking directly into the laser should be avoided. Avoid looking straight into direct reflections of reflecting surfaces (e.g. test base plate 2, Euler's disk 1, etc.). For further information, please refer to the PDV-100 manual.

---

**Electrical connections**

For the electrical connections, please proceed as follows:

1. Connect the vibrometer (connector **Analog out**) and the junction box VIB-E-220 (connector **VELO**) to the BNC cable.
2. Connect the junction box VIB-E-220 to the USB input of a PC which already has the software package VibSoft-20 installed.
3. Connect the Hardlock for VibSoft-20 to the PC.
4. Connect the mains supply (power supply) to the vibrometer.
5. Switch the PC on and start VibSoft-20.

**Note:**

During all vibration experiments with the Euler's disk, note that the Euler's disk exhibits a preferred edge for the vibration. The edge of the disk with the greatest radius is intended to be the contact edge.

**Fine adjustment of the test base plate**

Depending on the position of the measurement point on the Euler's disk, velocity amplitudes of varying sizes are measured. The further away the measurement point is from the center, the greater the velocity amplitude and thus the measurement signal.

1. Start the Euler's disk vibrating.
2. Wait until the Euler's disk comes to a standstill.
3. Now move the test base plate 2 (refer to FIGURE 3.2) with the Euler's disk so that the laser beam hits it approx. 1 cm from the edge of the Euler's disk (refer to FIGURE 3.3). While doing so, do not change the position of the Euler's disk on the test base plate!

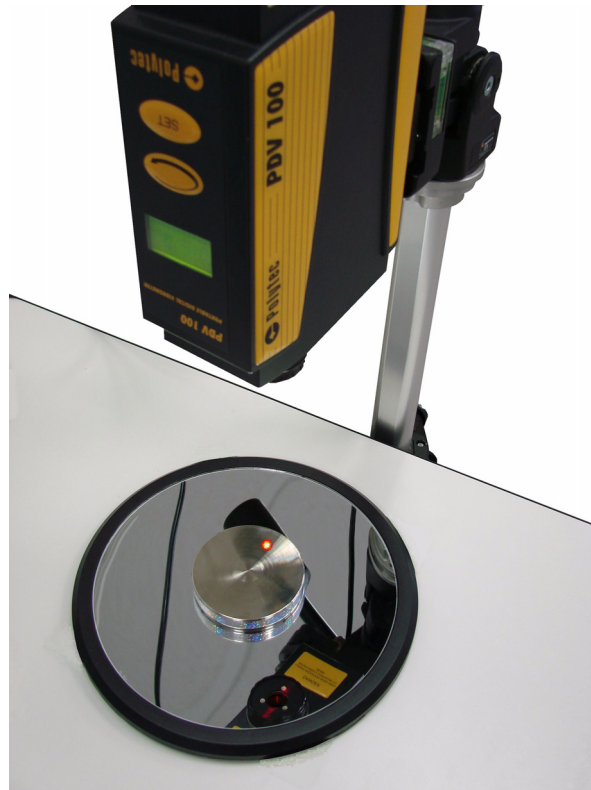

Figure 3.3: Euler's disk with laser sample point

### Focusing the laser beam

1. Focus the laser beam on the Euler's disk by rotating the focusing ring of the vibrometer. Focussing is optimal if the signal level display on the vibrometer reaches a maximum (at the same time the laser measurement point on the object is smallest).
2. Start the Euler's disk gyrating and check the signal level as soon as the Euler's disk is continuously hit by the laser beam. If required, correct the focus so that all the time the Euler's disk is moving, the signal level is as good as possible.

### Advice if the signal level is low:

- It is possible that the signal level display does not display anything for approx. the first half of the gyrating movement. A measurement is possible in these cases if the signal level is at a maximum when the Euler's disk is at a standstill. Please pay attention to the following points and continue with the experiment.
- Check whether the vibrometer looks like it is aligned at right angles to the test base plate. If the vibrometer is at a different angle, then not much light is reflected from the Euler's disk to the vibrometer which causes a bad signal level.
- Check the distance between the vibrometer and the Euler's disk with regards to visibility maxima of the laser. Refer to the Chapter Optimal stand-off distances in the vibrometer manual.

### 3 Experiment Euler's Disk

#### Measurement duration and vibration frequency

To estimate the measurement duration and vibration frequency, please proceed as follows:

1. Determine the total vibration duration of the Euler's disk approximately by setting it into motion several times and making a time measurement until it is at a complete standstill. The vibration duration is required for presetting the measurement time later on in the experiment (guideline value  $t = 50 \dots 120 \text{ s}$ ).
2. Make an initial estimate of the maximum gyration frequency based on the theory of a rigid, thin disk around its center of mass (equation (3.2)). During the vibration process, observe the disk from the side. From the deviation  $u$  of the edge of the disk and the diameter  $2r$  of the disk, it is possible to (very) roughly estimate the tilt angle of the disk just before standstill. The radius of the Euler's disk  $r = 37.5 \text{ mm}$  and the height of the Euler's disk  $h = 12 \text{ mm}$  are given.

#### Notes on implementation:

When observing the gyrating Euler's disk from the side, there appear to be two Euler's disks in opposing vibration positions. As the amplitude of the gyrating vibration decreases, the two images run into each other and allow a rough estimation of the vibration amplitude in relation to the thickness  $h$  of the Euler's disk.

#### Result

It is recognizable that the swing  $u$  shortly before the Euler's disk is at a standstill is  $< 1/10$  of the thickness of the disk  $h$ . If you estimate the swing  $u$  to be approx.  $1/20$  of the disk thickness and replace in equation (3.1)  $\sin(\alpha) = (u/2r)$ , then as an estimated value for the maximum vibration frequency, you will get  $f_{\text{max}} = 58 \text{ Hz}$ .

### 3.3 Carrying Out the Experiment

#### 3.3.1 Parameter Settings on the Vibrometer

Before making a measurement, set the following parameters on the vibrometer:

- Velocity measurement range (20/100/500  $\frac{\text{mm}}{\text{s}}$ )
- Low pass filter (1/5/22kHz)
- High pass filter 100Hz (On/Off)

The setting is made directly on the vibrometer using the arrow key and the key Set.

#### Preliminary considerations

Which settings would be sensible for the three above mentioned parameters?

#### Result a)

The vertical vibrational velocity of any point on the Euler's disk results from the following considerations. On the one hand, the vibrometer laser beam "sees" an angular vibration of the Euler's disk around the axis  $z_k$  (refer to FIGURE 3.1). On the other hand, the vibration displacement of the tilt vibration can approximately be described as

$$s(t) = \alpha \cdot r_{\text{meas}} \cdot \sin(2\pi ft) \quad \text{Equation 3.5}$$

with  $r_{\text{meas}}$  as the distance of the measurement point from the center of the Euler's disk and  $f$  as the gyrating frequency. From this, the vibrational velocity can be derived:

$$v(t) = \alpha \cdot r_{\text{meas}} \cdot 2\pi f \cdot \cos(2\pi ft) \quad \text{Equation 3.6}$$

with the maximum:

$$v_{\text{max}} = \alpha \cdot r_{\text{meas}} \cdot 2\pi f \quad \text{Equation 3.7}$$

With a constant  $r_{\text{meas}}$  the vibrational velocity is greatest when the product ( $\alpha \cdot f$ ) is maximized. However, the tilt angle  $\alpha$  and the vibration velocity  $f$  over time behave conversely. With a large tilt angle  $\alpha$  the vibrational velocity is low and vice versa. By rewriting the equation (3.1) it can be shown that the product ( $\alpha \cdot f$ ) at a small frequency  $f$  (and a large angle  $\alpha$ ) of the Euler's disk is maximized. The following starting conditions are assumed:

- Radius of the Euler's disk:  $r = 37.5 \text{ mm}$
- Swing:  $u = 15 \text{ mm}$  (refer to FIGURE 3.1)
- Distance measurement point from center of the Euler's disk:  
 $r_{\text{meas}} = 27.5 \text{ mm}$

According to equation (3.1) the gyration frequency for  $f = 11.5 \text{ Hz}$ . According to equation (3.7) the maximum vibrational velocity for  $v_{\text{max}} = 400 \frac{\text{mm}}{\text{s}}$ . Choose the largest velocity measurement range from 500  $\frac{\text{mm}}{\text{s}}$  on the vibrometer (Display menu item **Velo**).

**Result b)** The low pass filter suppresses high-frequency parts of the vibration. As estimated in the previous section, the maximum vibration frequency of the Euler's disk is expected to be clearly less than 1 kHz. For this reason, select the setting 1 kHz for the low pass filter on the vibrometer (Display menu item **LP**).

**Result c)** The high pass filter suppresses low-frequency parts of the vibration (cutoff frequency 100Hz). As the vibration frequency of the Euler's disk to be expected is in the low-frequency range, switch the high pass filter off. This corresponds to the setting N (Display menu item **HP**).

### 3.3.2 Vibration Measurement in the Time Domain

#### 3.3.2.1 Configuring the Software

To make changes to the measurement parameters, click **A/D** in the toolbar of the application window. The dialog Acquisition Settings appears.

**General** 1. Display the page General.

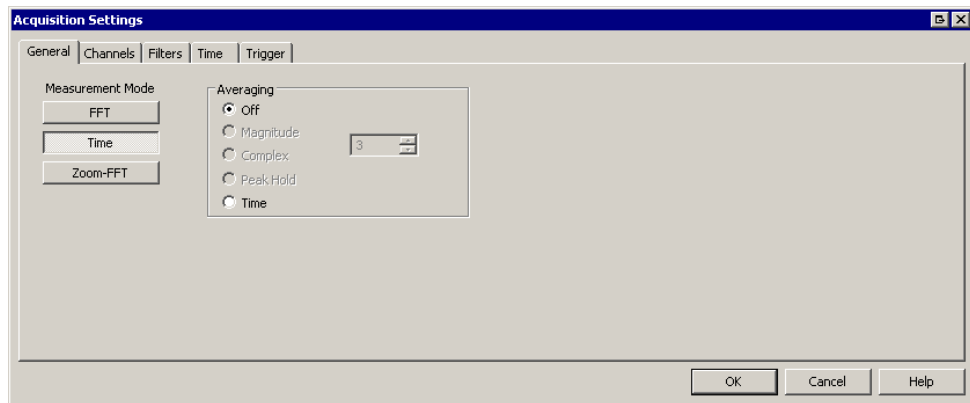

Figure 3.4: Dialog Acquisition Settings, page General

2. Select Time as the measurement mode and also No Averaging



Channels

3. Display the page Channels.

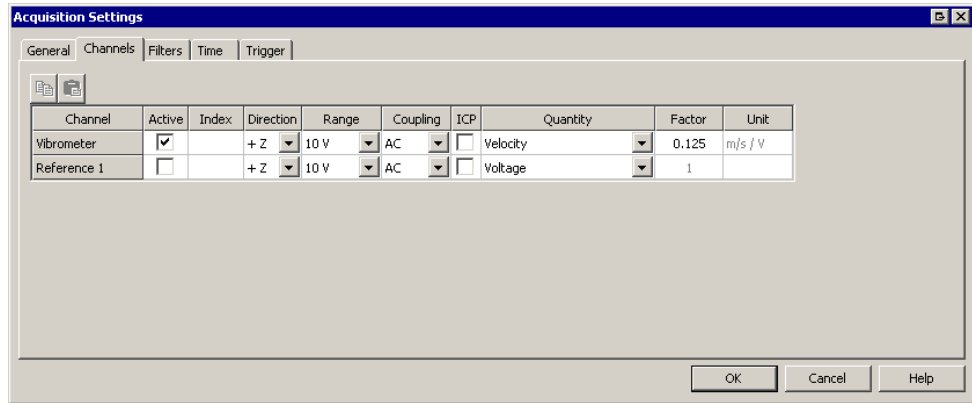

Figure 3.5: Dialog Acquisition Settings, page Channels

4. In the line Vibrometer tick the check box Active and deactivate the check box ICP.
5. Select Velocity in the list Quantity and the factor  $0.125 \frac{\text{mm}}{\text{s}}/\text{V}$ .
6. In the line Reference 1, deactivate the check box Active (refer to FIGURE 3.5).
7. Note on factor:

The factors is calculated using the following equation:

$$\text{Factor} = \frac{\text{Measurement range of the vibrometer}}{\text{Maximum voltage signal}}$$

The voltage range at the vibrometer output is  $\pm 4 \text{ V}$ . Taking into account the measurement range of  $500 \text{ mm/s}$  set in SECTION 3.3.1, this results in a calibration factor of  $0.125 \text{ m/s/V}$ . The calibration factors for the three possible measurement ranges of the PDV-100 are listed in TABLE 3.1.

Table 3.1: Measurement range of the PDV-100 and allocated calibration factors

Maximum measurement range in $\frac{\text{mm}}{\text{s}}$	Calibration factor in $\frac{\text{mm}}{\text{s}}/\text{V}$
500	125
100	25
20	5

**Filters**

8. Display the page Filters.

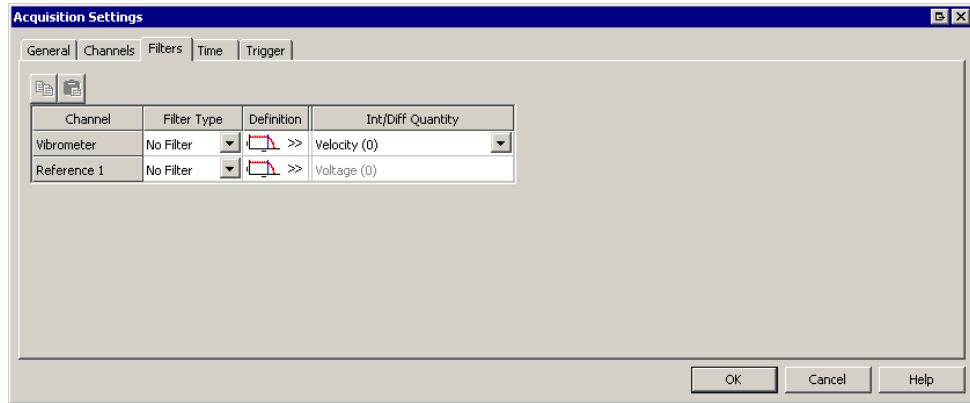

Figure 3.6: Dialog Acquisition Settings, page Filters

9. Deactivate the filters for the vibrometer channel (refer also to FIGURE 3.6).

**Time**

10. Display the page Time.

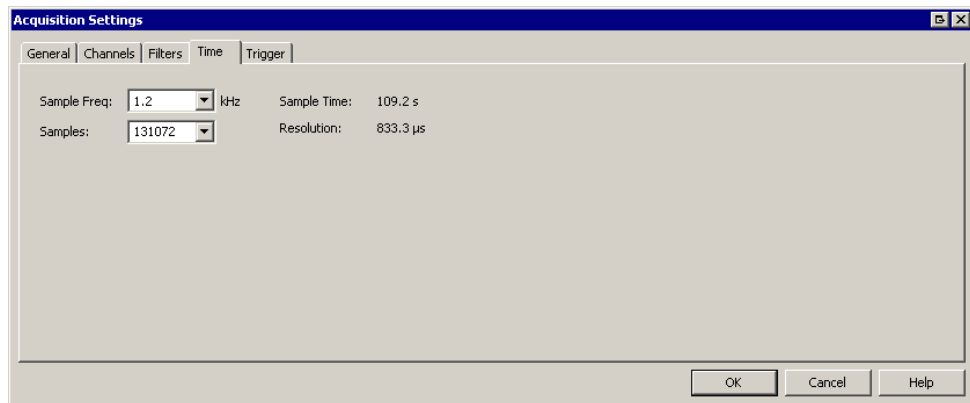

Figure 3.7: Dialog Acquisition Settings, page Time

11. Set the sample frequency so that the Nyquist criterion is reliably maintained at the highest vibration frequency of the disk (refer to SECTION 3.2) (sample frequency > 10x vibration frequency). Guideline value: Sample frequency = 1.2 kHz.
12. Select the number of samples so that the measurement time identified by the software is definitely enough to cover the vibration time of the Euler's disk determined in SECTION 3.2 (refer to FIGURE 3.7).

## Trigger

13. Display the page Trigger.

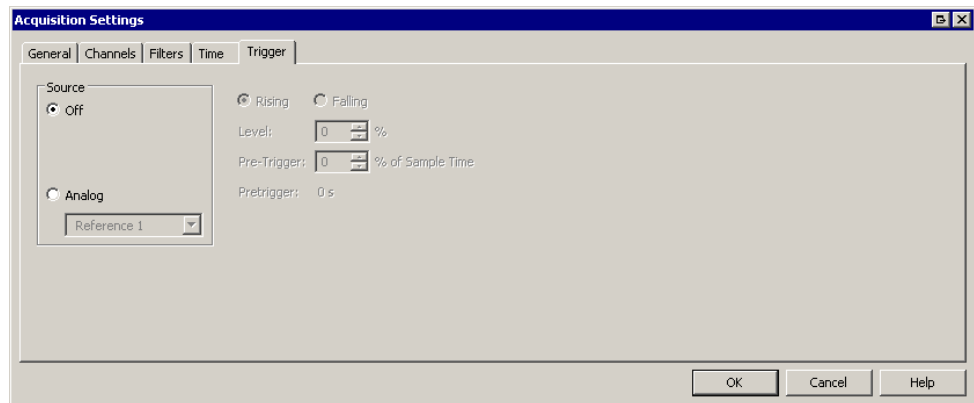



Figure 3.8: Dialog Acquisition Settings, page Trigger

14. Select Off as the source, as the measurement is being started manually (refer also to FIGURE 3.8).

### 3.3.2.2 Starting the Test Measurement and Checking the Measurement Range

You can make a test measurement as an individual measurement or as a continuous measurement. To do so, click  or  in the toolbar of the application window. Refer to your software manual on this as well.

Watch the time signal while the Euler's disk is vibrating. On the basis of the vibrational velocity shown, check whether the measurement range on the vibrometer can be reduced to  $100 \frac{\text{mm}}{\text{s}}$ .

**Comments:**

- If the measurement range on the vibrometer is changed, the calibration factor (refer to SECTION 3.3.2) also has to be adjusted.
- To minimize the noise level of the signal, choose a measurement range which is as small as possible.
- If the vibrational velocity of the object exceeds the selected measurement range, then the measurement signal is overloaded. In this case, select a larger measurement range. FIGURE 3.9 shows on the left the measurement signal in the correct measurement range  $500 \frac{\text{mm}}{\text{s}}$  and on the right the same measurement signal in the measurement range  $100 \frac{\text{mm}}{\text{s}}$  with significant overloading. The signal shape is distorted.

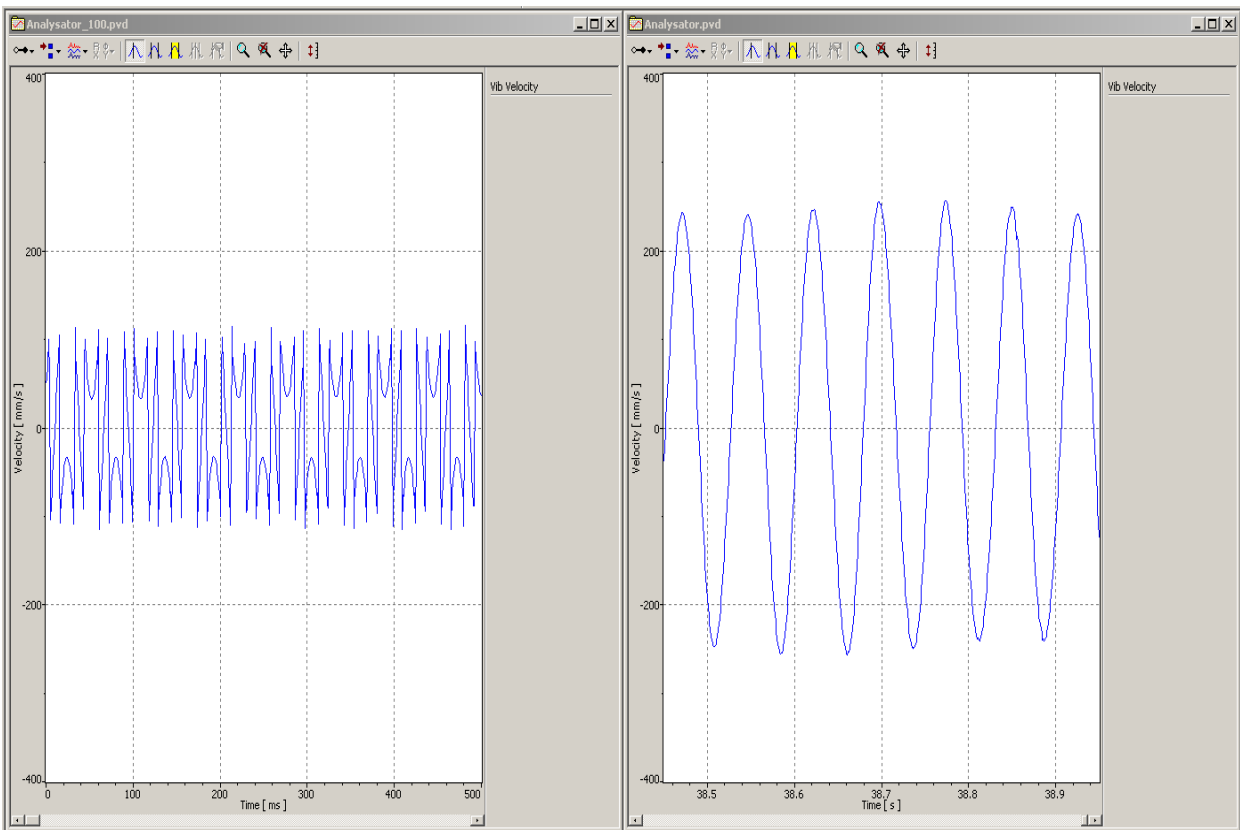

Figure 3.9: Measurement result with adjusted (l.) and overloaded (r.) measurement signal

- Change the settings for the high and low pass filter on the vibrometer and check to see if you can find better values.

### 3.3.2.3 Making Measurements

To make the measurement, please proceed as follows:

1. Set the Euler's disk in motion and start the individual measurement as soon as the laser continuously hits the Euler's disk.

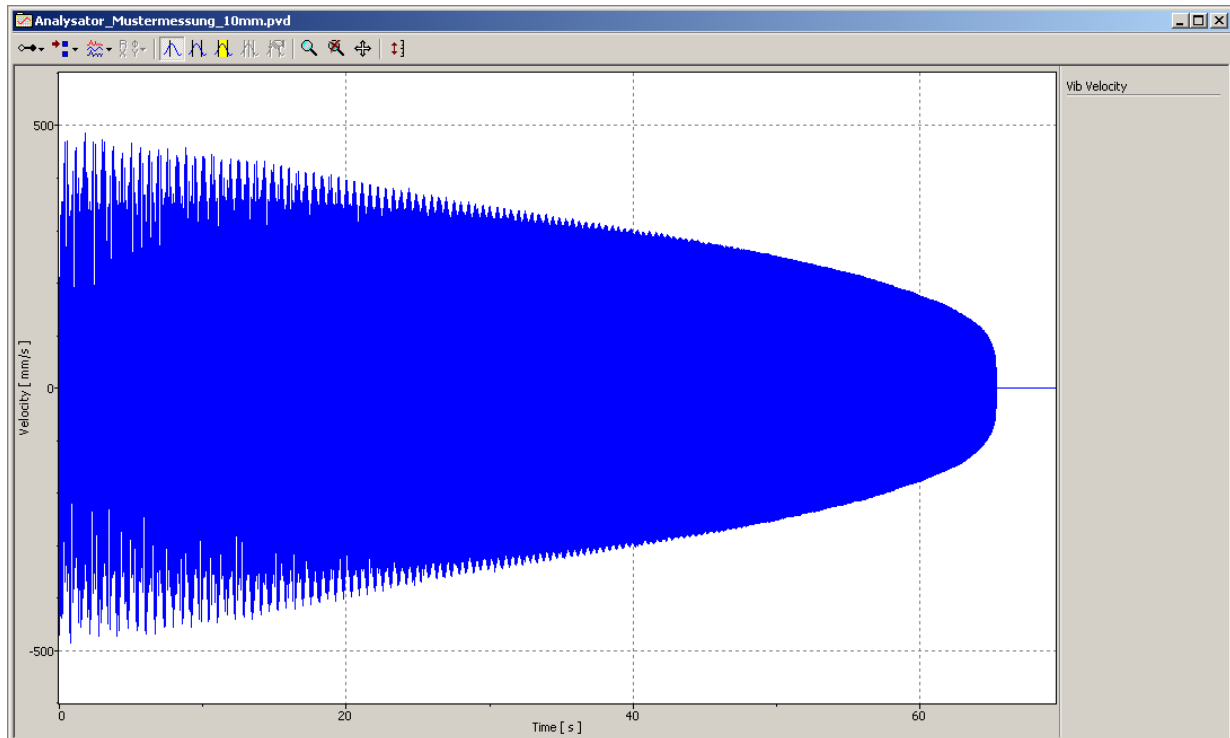

Figure 3.10: Measuring a complete vibration cycle of the Euler's disk in the time domain

2. Save the measurement data under the file name `Measurement_Time Domain.pvd` for analysis at a later point in time.
3. Mark the location of the laser measurement point on the Euler's disk with a permanent pen.

#### Exercises/ Questions

- How does the velocity amplitude behave over time?
- Watch the signal response in sections of time (start of vibration, middle, just before Euler's disk falls over) by zooming in the signal. What qualitative changes are there in the vibration at the start and the end of the measurement? What causes the difference you can see? Repeat the measurement and compare the effects recognized in the measurement signal with the real movement of the Euler's disk.

### 3 Experiment Euler's Disk

#### Result

- A reduction in the vibration amplitude over the course of time can clearly be seen in the measurement signal. At the end of the vibration, the amplitude distribution shows distinctly nonlinear behavior. If you zoom in on different areas of the measurement signal, an increase in the vibration frequency becomes obvious.
- A more precise look at the middle of the time signal reveals another effect: The measurement signal appears to be modulated (refer to FIGURE 3.11). This effect can be explained as follows:

At the start of the vibration, in addition to the gyrating movement, the Euler's disk also performs a low-frequency precessional motion on the level. The laser beam scans the Euler's disk at various points during the precessional motion. Through this precessional motion, the distance between the laser beam and the center of the Euler's disk changes cyclically.

The change in the measurement location causes a change in the vibration amplitude measured which becomes visible as a superimposed vibration in the measurement signal. Because of the test base plate designed as a concave mirror (watchglass) the Euler's disk is centered to the middle of the plate during the course of the gyrating movement and the precessional motion fades.

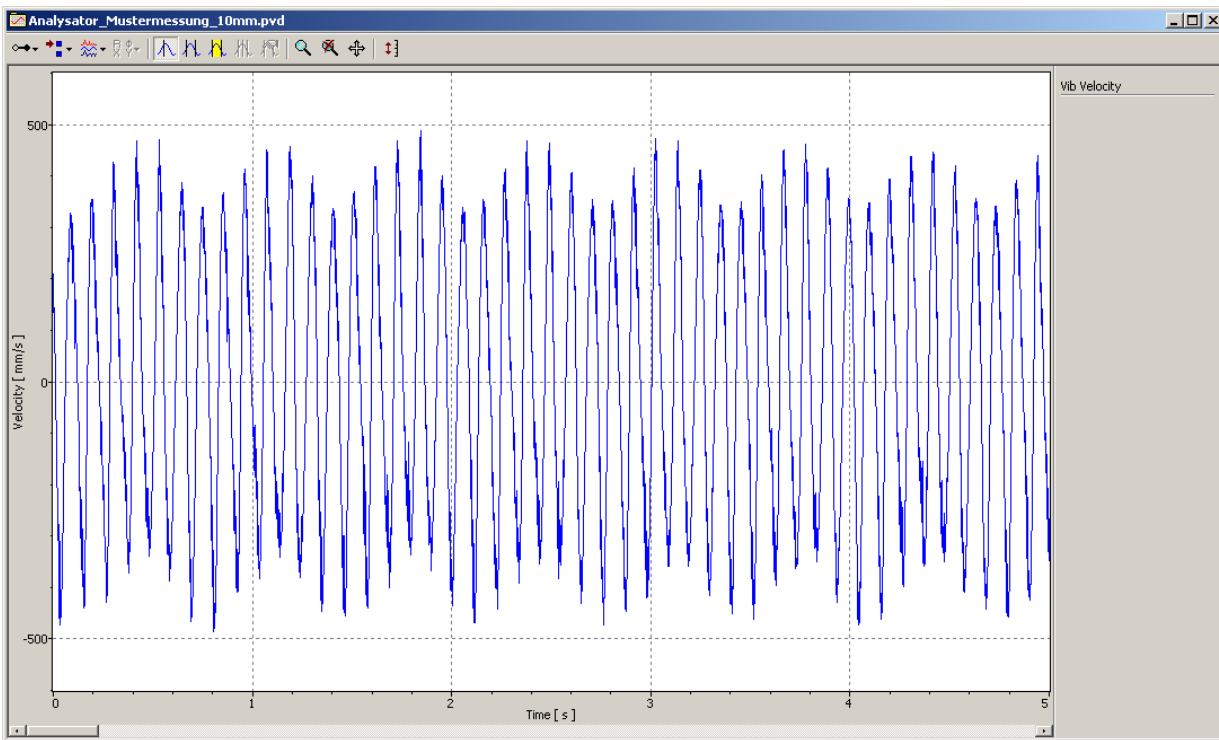



Figure 3.11: Measurement signal with superimposed precision vibration

**Other tasks**

- Check whether the modulation of the measurement signal can be caused by the precessional motion by comparing the order of magnitude of the frequencies!

In the VibSoft-20, the cycle duration of the harmonic can be determined with the differential cursor, the cycle duration of the precessional motion of the Euler's disk is to be estimated. The observed effect is examined in more detail in SECTION 3.3.6.

- Determine the vibration frequencies on three subsections with the aid of the differential cursor!
- Open the dialog Acquisition Settings by clicking  and display the page Time! Is it possible for the Nyquist criterion to be breached with the smallest sample frequency that can be set, taking the vibration frequencies determined into consideration?

Set the smallest possible sample frequency and make a new measurement! While doing so, compare the quality of the time signal shortly before the Euler's disk falls over - i.e. at maximum vibration frequency - with the previous measurement!

**3.3.3 Vibration Measurement in the Frequency Range**

Now measure the vibration of the Euler's disk in the frequency range. To make changes to the measurement parameters, click . The dialog Acquisition Settings appears.

**3.3.3.1 Configuring the Software****General**

1. Display the page General.

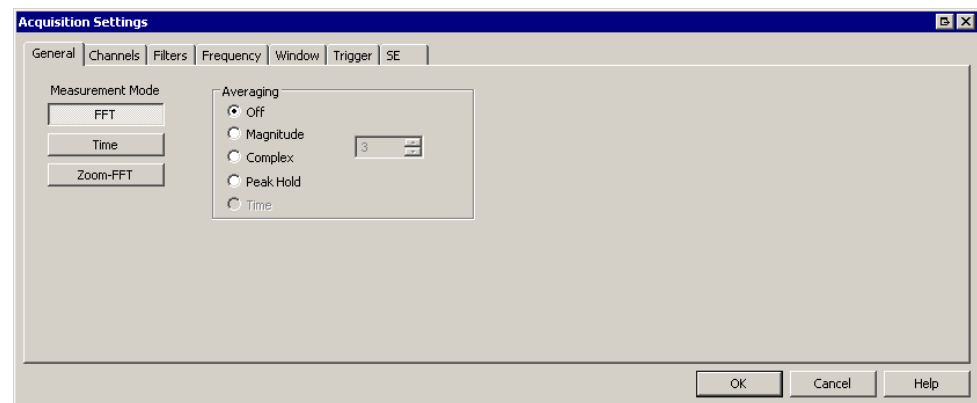

Figure 3.12: Dialog Acquisition Settings, page General

2. Select FFT as the Measurement Mode and also No Averaging

Frequency

3. Display the page Frequency.

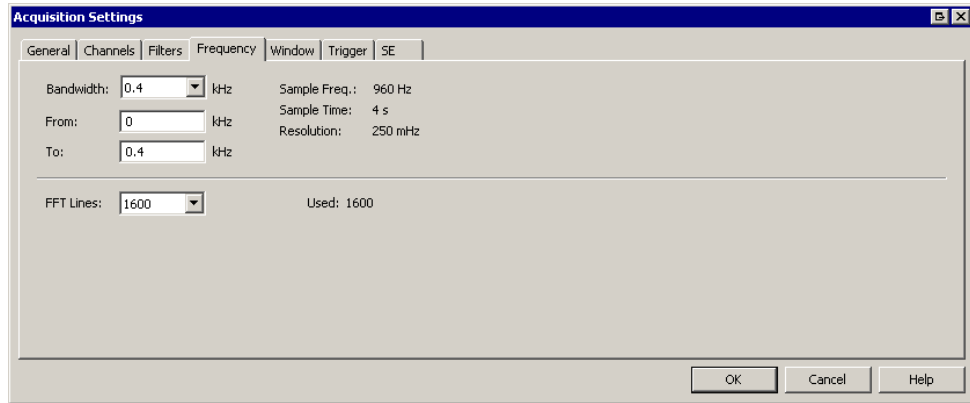

Figure 3.13: Dialog Acquisition Settings, page Frequency

4. Set the parameters to measure the frequency spectrum. Select the settings as shown in FIGURE 3.13.

The frequency range from 0 to 400Hz is sampled on 1600 FFT lines. The frequency resolution is 0.25Hz and is displayed by the software. Acquisition of the quantity of data necessary for this FFT quality requires a measurement time of 4 seconds. In the case of a continuous measurement, a frequency spectrum that is based on measurement data in this time frame is issued at 4 second intervals. An FFT analysis divides the data in the time domain into so-called slices of time, which are evaluated with respect to their frequency spectrum.

Window

5. Display the page Window.

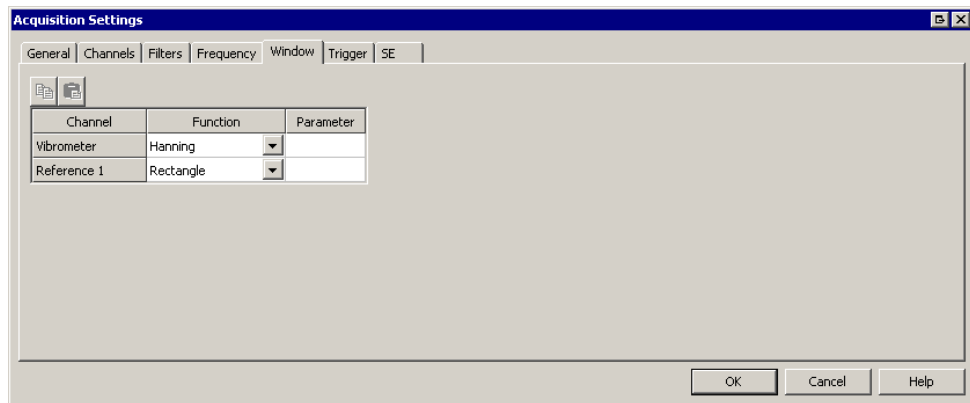

Figure 3.14: Dialog Acquisition Settings, page Window

6. Select Hanning as the function for the vibrometer channel (refer also to FIGURE 3.14).



### 3.3.3.2 Making Measurements

**Preliminary considerations** Which qualitative progress of the frequency spectrum do you expect for the successive time slices?

Switch the view of the graphic display from Time to FFT (refer to FIGURE 3.15). Set the Euler's disk in vibration and start a continuous measurement. How does the velocity spectrum develop over time? Do the measurement results meet your expectations?

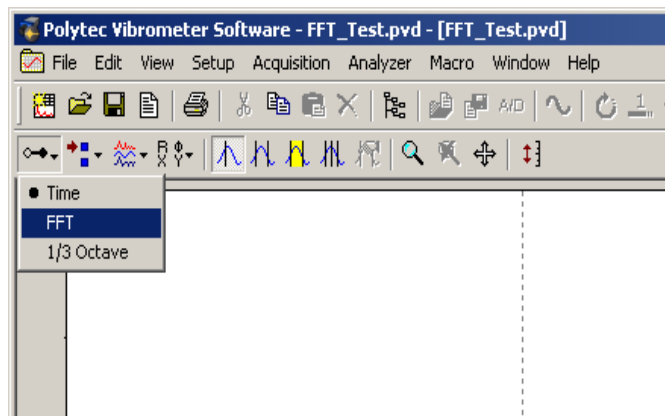

Figure 3.15: Mode of the graphics display

#### Result

- The vibration frequency increases over time while the velocity amplitude decreases.
- While at the beginning a pronounced, symmetrical peak can be seen at a vibration frequency, later on the spectrum appears to be increasingly asymmetrical (refer to FIGURE 3.16).

#### Exercises/ Questions

- What conclusion can be drawn from the observed change of the FFT spectrum on the linearity of the frequency change over the time?
- How can the asymmetric progress of the FFT spectrum be reduced at least from a metrological point of view?

### 3 Experiment Euler's Disk

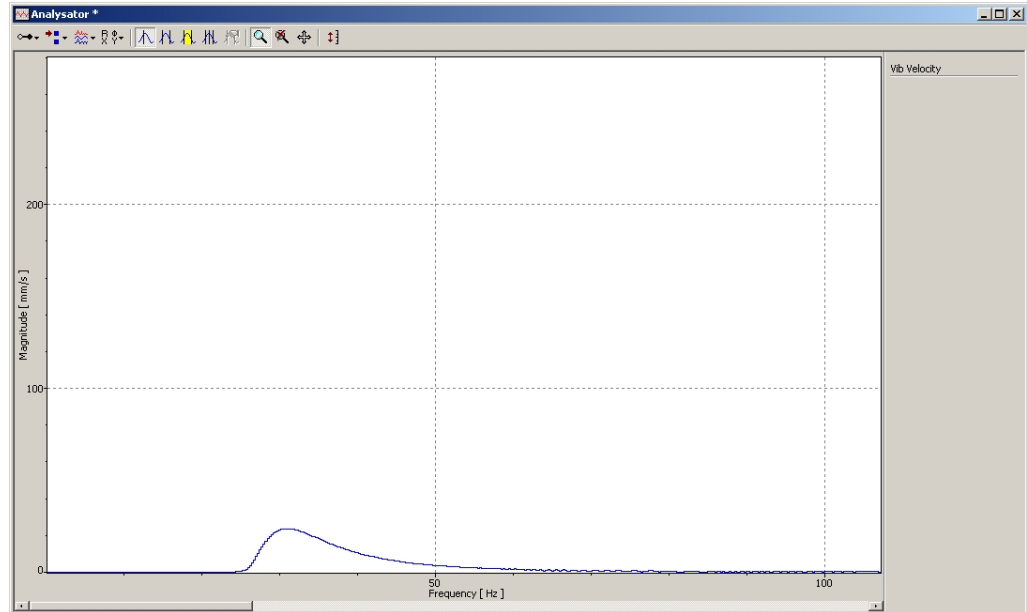

Figure 3.16: FFT spectrum near the end of the vibration of the Euler's disk

Change the number of FFT lines in the dialog Acquisition Settings on the page frequency to 400 lines for example. How does the measurement time change? Repeat the measurement. What changes can be seen in the time response of the FFT spectrum?

#### 3.3.4 Relationship between Vibration Amplitude and Vibration Frequency

Equation (3.1) describes the relationship between the gyrating frequency and tilt angle of the Euler's disk. What is noteworthy is that this relationship only depends on the physical properties of the Euler's disk, not however on influences that can be manipulated, such as the initial angular momentum for example.

##### Task

Evaluate the measurement saved from SECTION 3.3.2 using the signal processor from VibSoft-20 or VibSoft Desktop. Examine the following relationship:

- Change in the vibration frequency over the course of time
- Relationship between vibration amplitude and vibration frequency
- Show the relationship on a graph. For the relationship vibration amplitude - vibration frequency, add the expected progression according to the equation (3.2).

##### Instructions for the signal processor

To use the signal processor, please proceed as follows:

1. Open the file Measurement\_TimeDomain.pvd in the software VibSoft-20 or VibSoft Desktop.
2. Click the data window with the right mouse button and select Copy in the context menu. The dialog Copy appears.
3. Select Signal processor and click OK (refer to FIGURE 3.17). The data is copied into the signal processor.

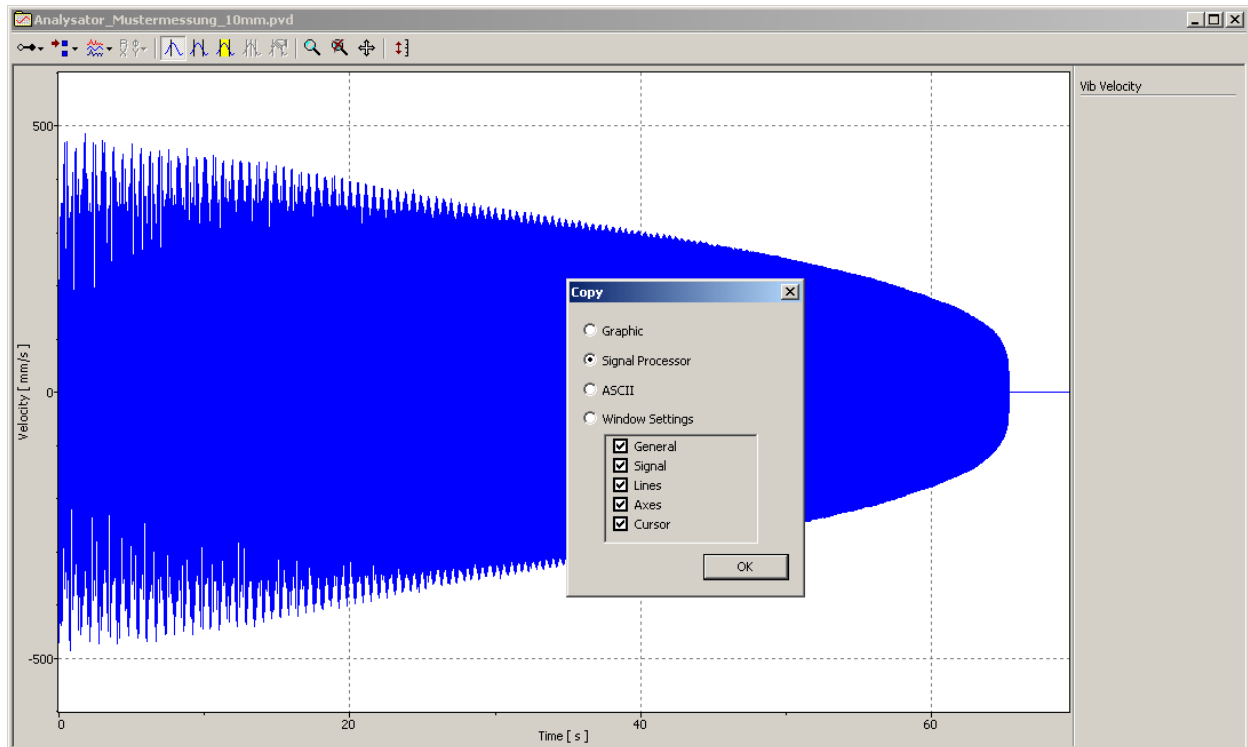

Figure 3.17: Copying the time data into the signal processor

4. To open the signal processor, select File > New > Signal processor. The signal processor appears. The signal processor is made up of a table area and a graphics area below that (refer to FIGURE 3.18).

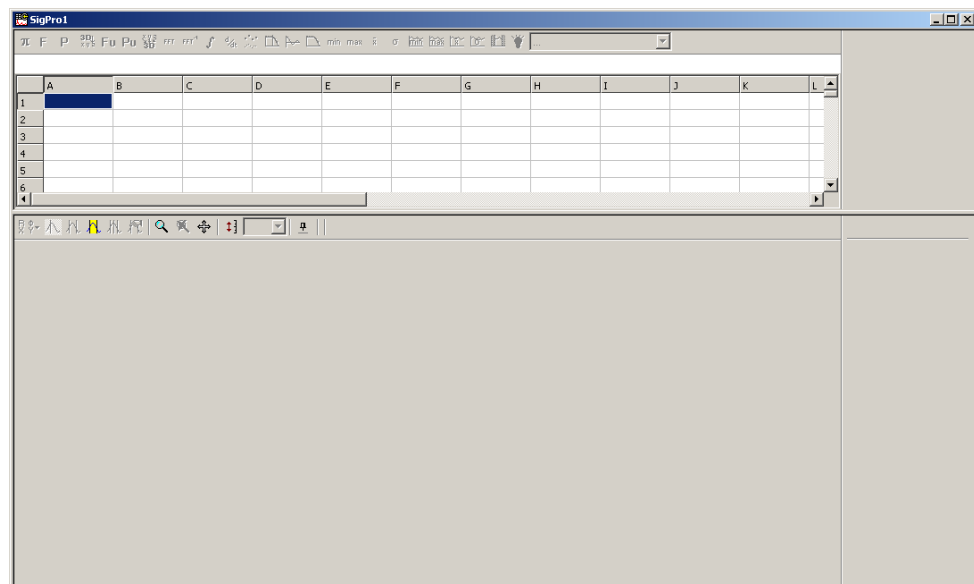

Figure 3.18: View of signal processor

5. Add the measurement data you have already copied into the field A1. To do so, click the field A1 with the right mouse button and select Insert in the context menu.





### 3 Experiment Euler's Disk

To display the vibration displacement, the vibrational velocities are integrated in line 4.

10. To do so, mark the field A4 and click  in the toolbar of the signal processor (refer to FIGURE 3.22). The function wizard appears.
11. Enter A3 as the data basis for VibData.

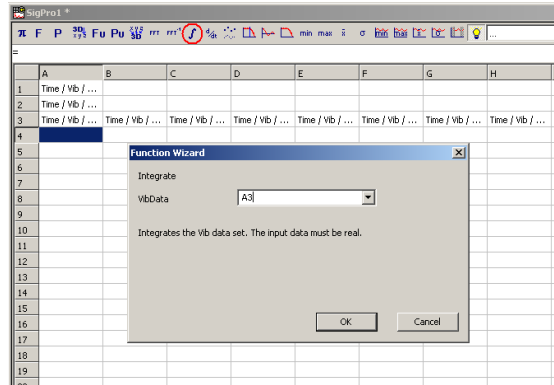

Figure 3.22: Integration of the velocity data in the signal processor

12. Repeat steps 8 to 11 for the other columns in line 4.
13. Mark the field A4. The displacement data of the vibration is shown in the graphics area of the signal processor.

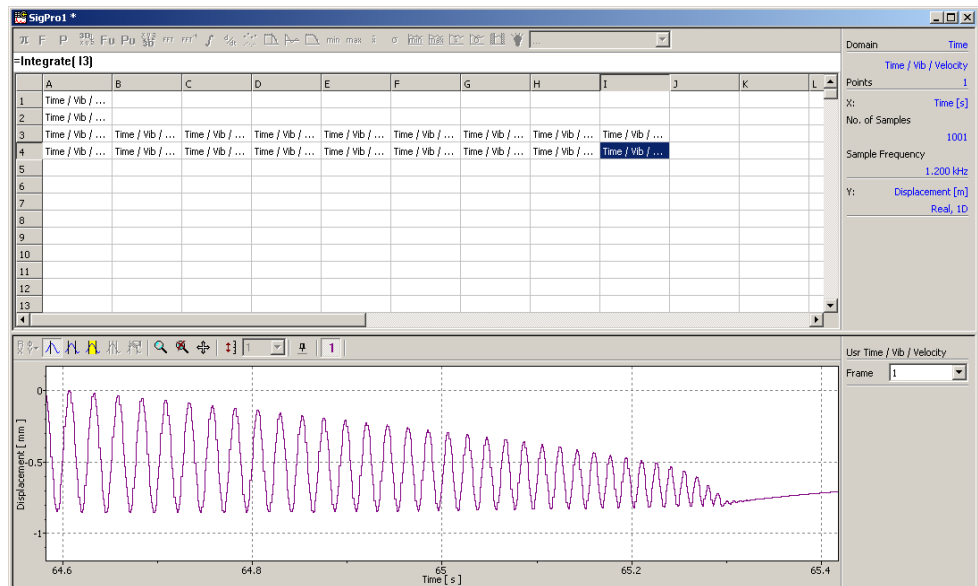

Figure 3.23: Showing the vibration displacement in the signal processor

14. Determine the data necessary for the task from the graphic representations of the individual measurement data ranges. Use the differential cursor to determine the data (refer to FIGURE 3.24).

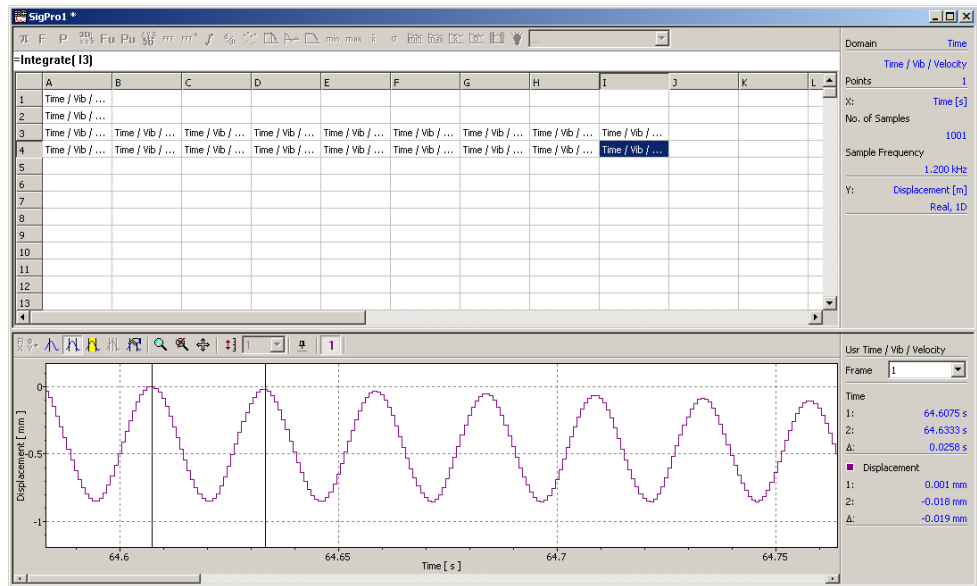

Figure 3.24: Data evaluation with the differential cursor

**Result**

The relationship between vibration frequency and vibration time or respectively vibration frequency and vibration amplitude are shown in FIGURE 3.25 or FIGURE 3.26 respectively.

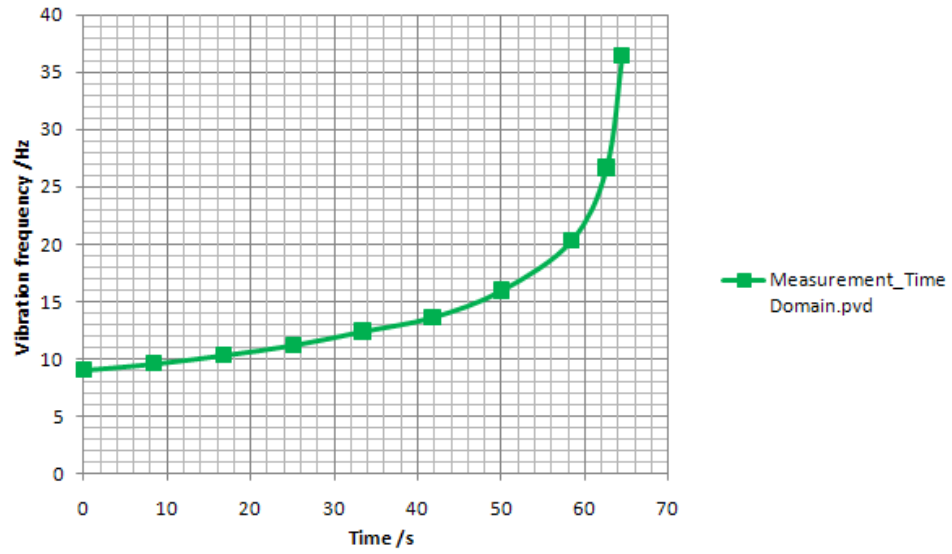

Figure 3.25: Relationship between vibration frequency and vibration time

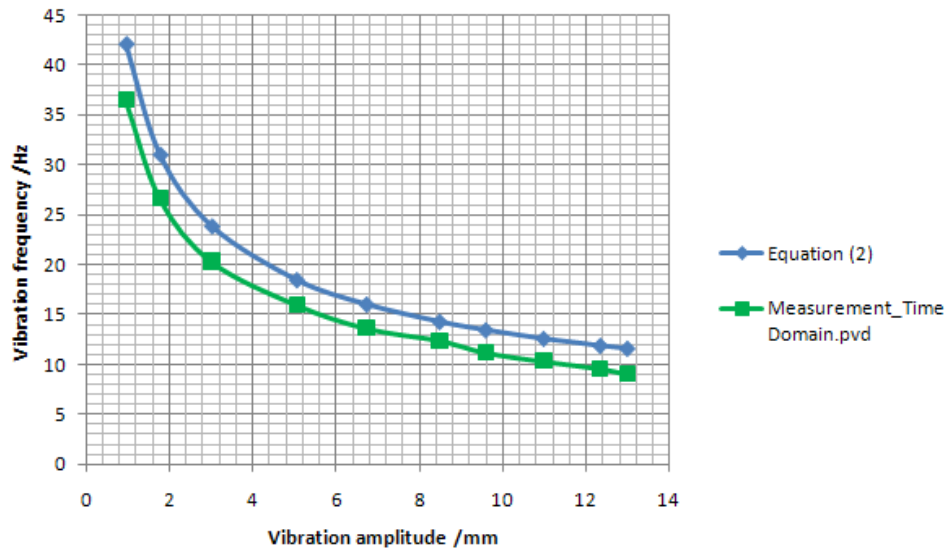

Figure 3.26: Relationship between vibration frequency and vibration amplitude



### 3.3.5 Effect of Window Function on the FFT Spectrum

To examine the effect of window functions on the FFT spectrum, please proceed as follows:

1. Load the data from the file Measurement\_TimeDomain.pvd into field A1 of a new signal processor.
2. In field A2, use the command `Exact()` to select all the measurement data that is to be used for the analysis - as a general rule all the vibration of the Euler's disk.
3. In line 3 use the command `Exact()` to select several measurement data sections with a width of 2000 sample points.
4. To carry out an FFT analysis in line 4 of the data ranges from line 3, mark the field A4 and click **FFT** in the toolbar of the signal processor. The function wizard appears.

Select the following parameters:

VibData:	A3
Lines:	400
Window:	Hanning

5. Repeat step 4 for the other columns in line 4.
6. Repeat the above procedure in line 5. However, here you select the window function `Rectangle` (Window: `Rectangle`).

By marking several fields in lines 4 and 5 at the same time, you can now directly compare the results of various FFT analyses in the graphics area.

#### Exercises

- Compare the individual FFT analyses with Hanning windows with each other (line 4). Do the results correspond to the experience gained in the measurement made in SECTION 3.3.3.2?
- Compare the dependency of the FFT spectrum of the selected window function by marking two FFT analysis in the same column. These are now shown graphically superimposed on each other (refer to FIGURE 3.27).

### 3 Experiment Euler's Disk

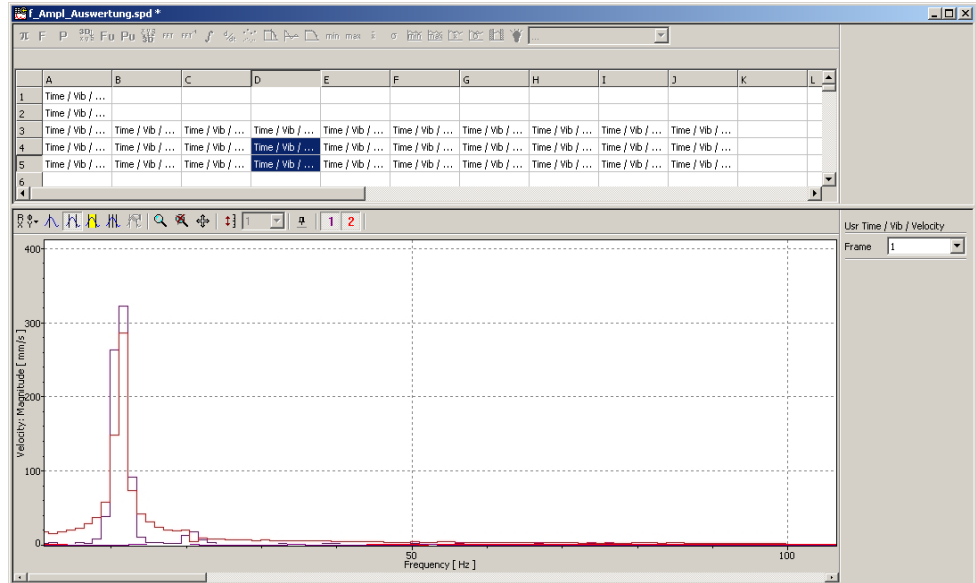

Figure 3.27: Effect of the window function on the FFT analysis

- Mark all fields in line 4! Compare the amplitudes of the FFT analysis with the amplitudes in the time signal (line 2)!

#### 3.3.6 Effect of the Precessional Motion of the Euler's Disk on the Measurement Signal

As ascertained in SECTION 3.3.2.3, the Euler's disk also carries out a precessional motion on the level as well as the gyrating movement. The precessional motion is greatest straight after setting the Euler's disk in motion and soon fades away, supported by the test base plate designed in the shape of watch glass which allows the Euler's disk to travel to the lowest point. The precessional motion that is superimposed in the gyrating movement leads to 2 effects:

- Effect 1: Amplitude modulation of the measurement signal in the frequency of the precessional motion

FIGURE 3.28 shows the Euler's disk at two positions in its precessional motion around the axis  $z_p$  as well as the spatially fixed laser beam. It becomes clear that the measurement location in Pos. 1 is close to the center of the Euler's disk; in Pos. 2 in contrast, it is near to the edge. Consequently in Pos. 2 greater vibration displacement (speeds) are measured. The precessional motion thus has the effect that the vibration amplitude measured varies in the frequency of the precessional motion.

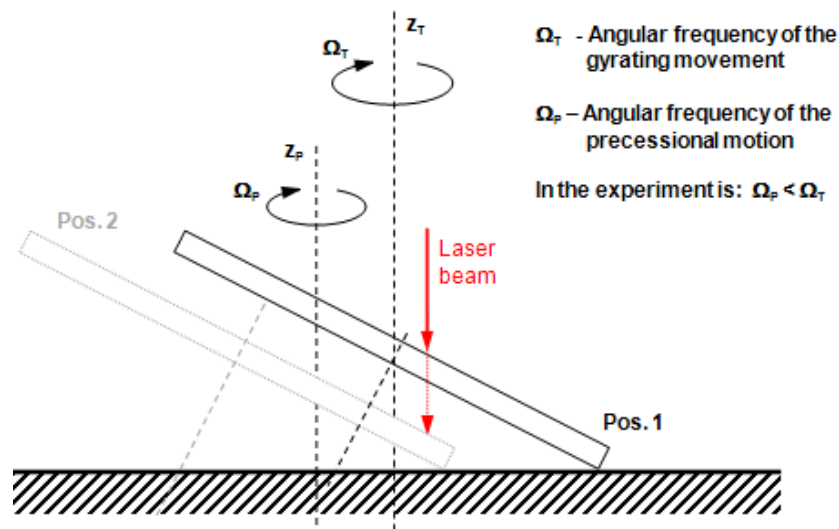

Figure 3.28: Measurement situation with precessional motion and perpendicular laser beam

- b) Effect 2: FIGURE 3.29 makes clear another effect of the precessional motion on the measurement signal. If the laser beam is not aligned absolutely at right angles to the test base plate, then apart from the vertical vibration (caused by the gyrating movement), a fraction  $x_h$  of the horizontal disk movement (caused by the precessional motion) is also measured. The measurement signal is made up of two superimposed 2 vibrations.

The same effect in the measurement signal is also observed with the (theoretically) absolutely perpendicular alignment of the laser beam (refer to FIGURE 3.30). Because of the test base plate being concave and not flat, the precessional motion effects a vertical movement of the Euler's disk between levels  $h_1$  and  $h_2$ , which are shown in the measurement signal as superimposed vibration.

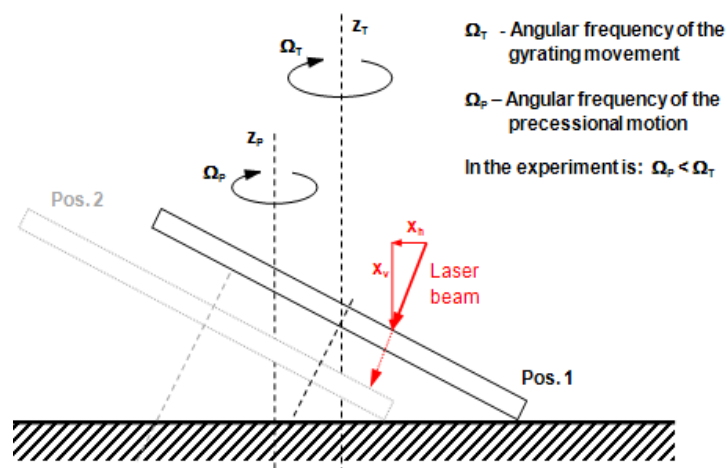

Figure 3.29: Measurement situation with precessional motion and angled laser beam

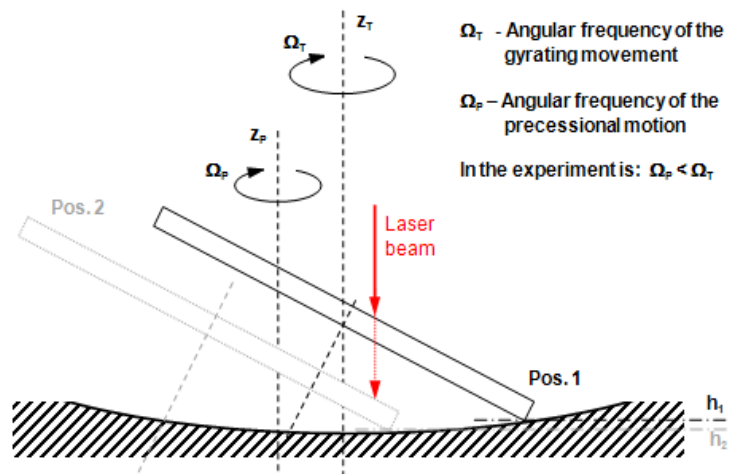

Figure 3.30: Measurement situation with precessional motion on concave test base plate

**Advanced considerations on further examination of the effect**

What signals do you qualitatively expect from the effects described under a) and b)? Look at the time and frequency range. Simulate the signals in the time domain, if necessary with the aid of a table calculation, e.g. Microsoft-Excel. To do so, set  $\Omega_T = 10\Omega_P$ .

**Result a)**

The gyrating movement can be described as a sinus function with the amplitude A as follows:

$$y(t) = A \cdot \sin(\Omega_T \cdot t) \quad \text{Equation 3.8}$$

The amplitude A in turn is a sinusoidal vibration with the precessional frequency:

$$A(t) = A_P \cdot \sin(\Omega_P \cdot t) \quad \text{Equation 3.9}$$

Equation (3.9) inserted in equation (3.8) results in:

$$y(t) = A_P \cdot \sin(\Omega_P \cdot t) \cdot \sin(\Omega_T \cdot t) \quad \text{Equation 3.10}$$

Equation (3.10) lends itself to the interpretation of the signal in the time domain. To explain the signal in the frequency range, an alternative layout of equation (3.10) is suitable:

$$y(t) = 0,5A_P(\cos((\Omega_T - \Omega_P) \cdot t) - \cos((\Omega_T + \Omega_P) \cdot t)) \quad \text{Equation 3.11}$$

In the frequency range, 2 frequencies appear:  $(\Omega_T - \Omega_P)$  and  $(\Omega_T + \Omega_P)$ .

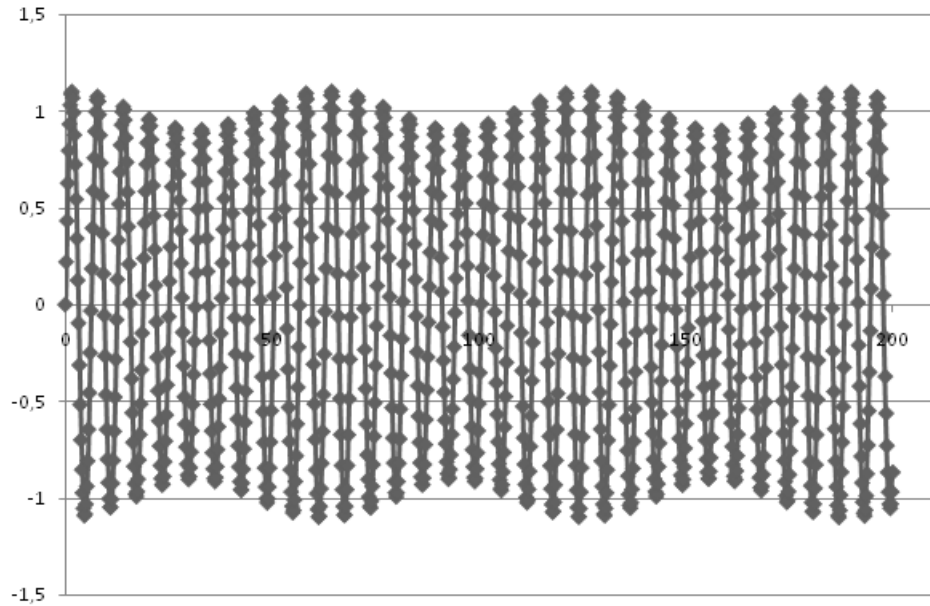

Figure 3.31: Effect a) - Amplitude modulation

**Result b)**

2 vibrations being superimposed can be shown directly as an addition of the 2 vibration signals:

$$y(t) = A_P \cdot \sin(\Omega_P \cdot t) + A_T \cdot \sin(\Omega_T \cdot t)$$

Equation 3.12

The interpretation of equation (3.12) represents a vibration with the precessional frequency  $\Omega_P$  in the time domain, upon which another vibration  $\Omega_T$  is modulated (refer to FIGURE 3.32). In the frequency spectrum the signal also receives the 2 frequencies.

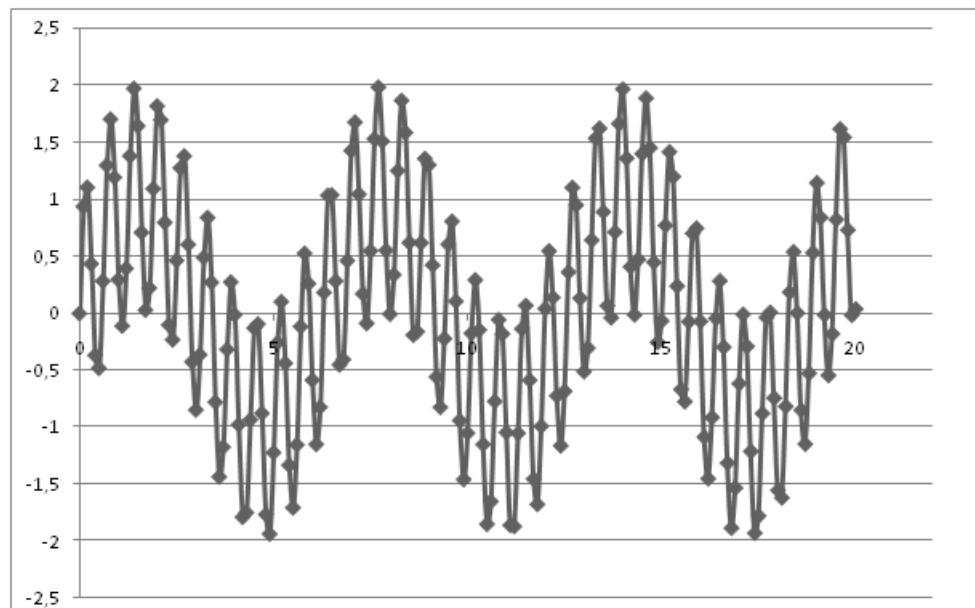

Figure 3.32: Effect b) - 2 superimposed vibrations

In the real experiment with the Euler's disk, both effects occur at the same time and can not be observed separately from each other. Therefore a mixed signal is to be expected with 4 significant frequencies in the frequency spectrum:  $\Omega_T$ ,  $(\Omega_T - \Omega_P)$ ,  $\Omega_P$  and  $(\Omega_T + \Omega_P)$ .

Check whether the observations made previously are correct by measuring the FFT spectrum in the experiment.

#### Notes on the measurement:

- To have as much time as possible available for the measurement, it is practical for this part of the experiment to sample the Euler's disk near the center (approx. 2 cm away from the edge of the disk).
- It is easier to observe the two-sided frequency split of the effect a) in  $(\Omega_T - \Omega_P)$  and  $(\Omega_T + \Omega_P)$ , if the laser beam is aimed at the Euler's disk at an angle of approx.  $20^\circ$  from perpendicular. As shown in FIGURE 3.29, the effect is amplified by this angle. If sampling is carried out at right angles, the frequency split is partially only clearly distinct on one side.
- Make sure that the measurement mode FFT is set and further settings in the dialog *Acquisition Settings* have been retained as described in SECTION 3.3.2.1 and SECTION 3.3.3.1.
- Set the Euler's disk vibrating at a high amplitude. According to equation (3.1), to do this, the disk no longer has to be started with a pulse, but can be left to its gyrating movement from an almost vertical position. Start an individual measurement as soon as the laser beam continuously captures the surface of the disk.

**Measurement result**

FIGURE 3.33 shows the FFT spectrum with the laser beam hitting at an angle of approx.  $20^\circ$ . You can see a peak in the range 1.75Hz (frequency of the precessional motion) as well as three peaks in the range 10Hz, which are around 1.75Hz apart (gyrating frequency split up by the frequency of the precession).

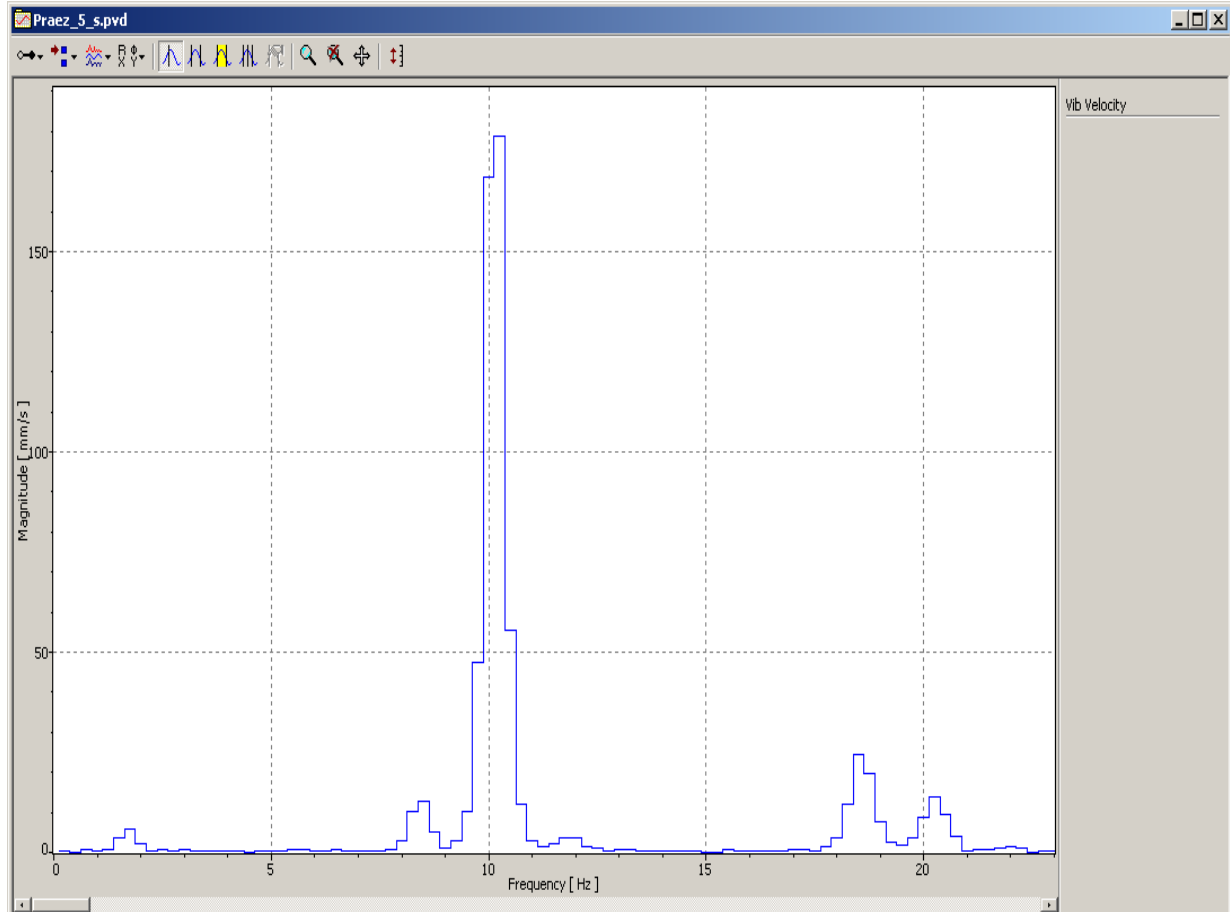

Figure 3.33: FFT spectrum of the amplitude modulated signal

### 3.3.7 The Vibration's Dependency on the Surface underneath the Test Base Plate

In the following, we investigate whether the surface that the test base plate is on has any impact in the duration of vibration, the vibration frequency and the vibration amplitude.

#### Preliminary considerations

Consider the results in SECTION 3.3.4. What effect on the relationship shown in FIGURE 3.25 and FIGURE 3.26 do you expect if you change the surface underneath the test base plate?

Carry out measurements in the time domain as described in SECTION 3.3.2, however with a modified experimental setup:

- a) with foam underlay - color anthracite - under the three feet of the test base plate
- b) with foam underlay - color gray - under the three feet of the test base plate

Save the measurement data.

#### Note:

So that you can compare the results with the previous measurements, it is necessary to set the measurement point the same distance away from the edge of the Euler's disk as for the previous measurements. For this purpose, allow the Euler's disk to vibrate 1x and set up the vibrometer once the Euler's disk is at a standstill in accordance with the mark which was applied in SECTION 3.3.2.3. The only thing that is important is the distance of the measurement point from the edge of the Euler's disk.

Evaluate the measurement data as described in SECTION 3.3.4.

#### Result

The time response of the vibration frequency depends on the selected surface (refer to FIGURE 3.34). Both types of foam underlay generate a different time response. The reason for this is the higher energy dissipation in both cases<sup>2</sup>. As expected, the relationship between vibration frequency and vibration amplitude in accordance with the equation (3.1) is not dependent on the surface selected (refer to FIGURE 3.35).

#### Note:

Because of the various manufacturing batches of the foam underlay, the individual measurement results can deviate from the results shown here.

---

<sup>2</sup> During the disk vibration with the soft foam underlay, vibration of the test base plate can clearly be seen. The vibration draws mechanical energy from the system through irreversible processes in the foam underlay.



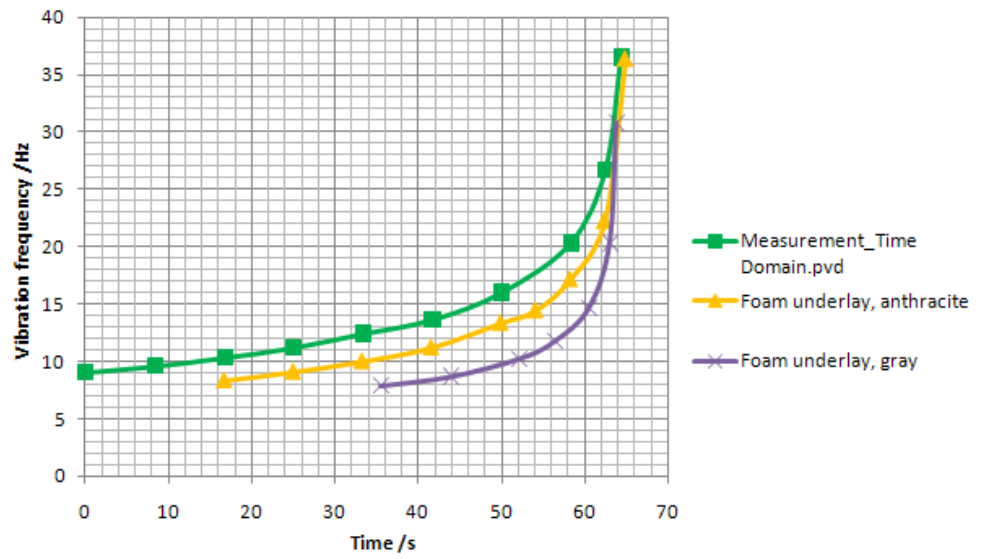

Figure 3.34: The effect of the foam underlay on the vibration frequency and vibration time

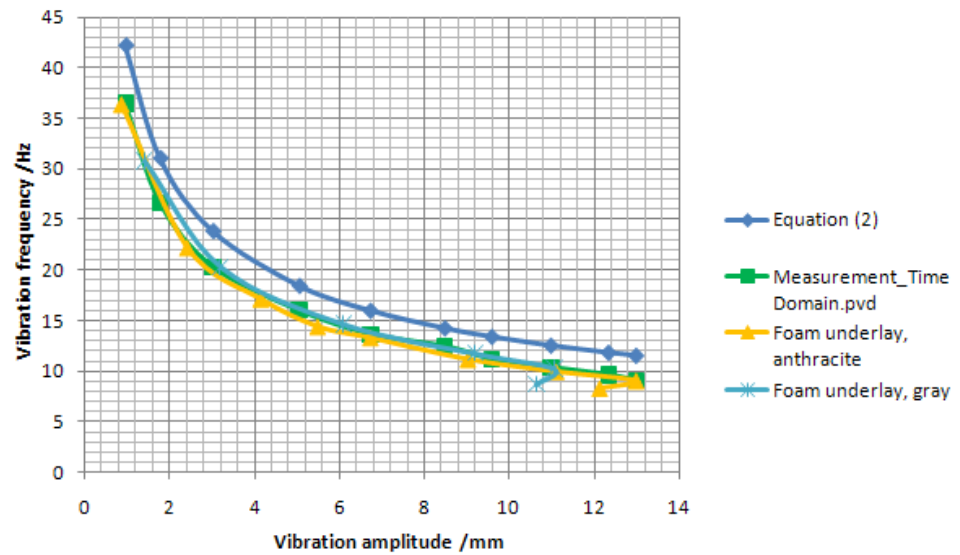

Figure 3.35: The effect of the foam underlay on the dependency of the vibration frequency on the vibration amplitude

### 3 Experiment Euler's Disk

## 4 Experiment Loudspeaker Characterization

### 4.1 Basics and Experiment Preparation

The PDV-100 Laser Doppler Vibrometer measures vibration frequencies from 0 Hz to 20 kHz, which covers the entire frequency range of acoustic vibrations. Because of this specification, the examination of acoustic vibration phenomena is an important application for the PDV-100 in science and industry. As an example of the field of application, in the following experiment, a loudspeaker membrane is examined with regards to its frequency response and deflection shapes.

1. The loudspeaker is excited using white noise. The frequency response of the loudspeaker is measured in the acoustic frequency range. Resonant frequencies are identified from the frequency response function (refer to SECTION 4.3.1).
2. The loudspeaker is excited with sinusoidal vibration of the resonant frequencies determined under point 1. By measuring the vibrational velocity of the loudspeaker membrane at several sample points, the respective deflection shape of the loudspeaker membrane can be estimated (refer to SECTION 4.3).
3. The linearity of the frequency response is examined while changing the volume.

#### Notes:

- The loudspeakers can have batch-related and individual differences with regards to their metrological properties. The measurement results from your individual loudspeaker can therefore vary from the results presented in the description of the experiment.
- To generate the excitation signals required for the experiments, you have the following options:

**Model 1:** We recommend generating the signal using a function generator.

**Model 2:** Playing back wav-files.

If no function generator should be available, the necessary excitation signals can be downloaded from [www.MyPolytec.net](http://www.MyPolytec.net) as wav files. Wav files can be played back using your PC's audioplayer, such as Windows Media Player.

Load the necessary wav files to prepare the experiment onto your PC.

**Model 3:** On the Internet you will find software for signal generation via the sound card of a PC offered as Freeware. You will find further information on this at [www.MyPolytec.net](http://www.MyPolytec.net).

**Volume and level settings**

For the recommended guideline values for the volume and level settings, please proceed as follows:

1. Set the volume regulator on the loudspeaker to a medium volume (nonius points vertically upwards).
2. When using a function generator (refer to Model 1), set the level of the excitation signal as follows:

Noise signals:  $1V_{\text{Peak-Peak}}$

Sinusoidal signals:  $0.1V_{\text{Peak-Peak}}$

**4.2 Experimental Setup**

For the experimental setup, select a stable, vibration-free and level test bench. The surface should allow you to be able to move the loudspeaker horizontally by 5 cm in any direction. FIGURE 4.1 shows the experimental setup with a function generator as the signal source.

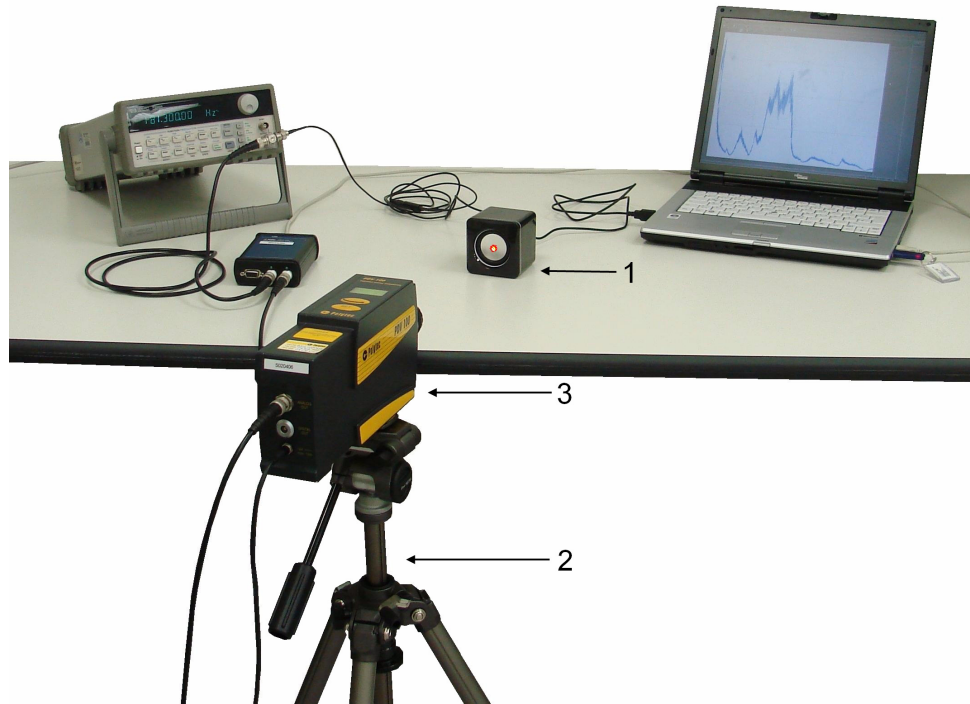

Figure 4.1: Experimental setup for loudspeaker characterization using a function generator

**Mechanical setup**

For the mechanical setup, please proceed as follows:

1. Position the loudspeaker box **1** on a level surface.
2. Assemble the tripod **2** next to the test bench.
3. To attach the vibrometer **3** to the tripod **2**, screw the tripod adapter plate (not shown) to the vibrometer (threaded hole 1/4"-20UNC). The adapter plate can now be fixed in place on the tripod head using the quick release mechanism.

- Align the vibrometer horizontally. The height of the vibrometer needs to be set so that the beam aperture is at the height of the loudspeaker membrane. The distance between beam exit aperture and the loudspeaker membrane should allow a visibility maximum. Refer to the Chapter Optimal Stand-off Distance in your PDV-100 user manual.

### Electrical connections

For the electrical connections, please proceed as follows:

- The connection diagrams for the experimental setups with and without function generator are shown in FIGURE 4.2 and FIGURE 4.3. Connect up the cables of the individual components in accordance with the model appropriate to you.



#### WARNING!

**Danger from laser light!** Connecting the mains supply to the vibrometer switches the laser on. The laser in the PDV-100 belongs to Laser Class 2 and is therefore safe for the user as a general rule. Despite this, looking directly into the laser should be avoided. Also avoid looking at direct reflections from reflective surfaces (e.g. the loudspeaker membrane). For further information, please refer to the PDV-100 manual.

- Connect the Hardlock for VibSoft-20 to the PC.
- Connect the main supply (power supply) to the vibrometer.
- Switch the PC on and start VibSoft-20.

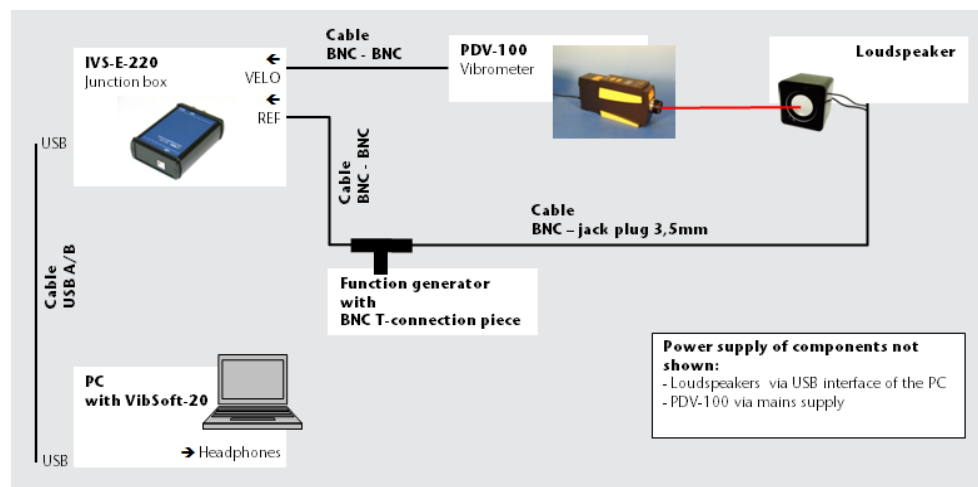

Figure 4.2: Connection diagrams for experimental setup with function generator

#### 4 Experiment Loudspeaker Characterization

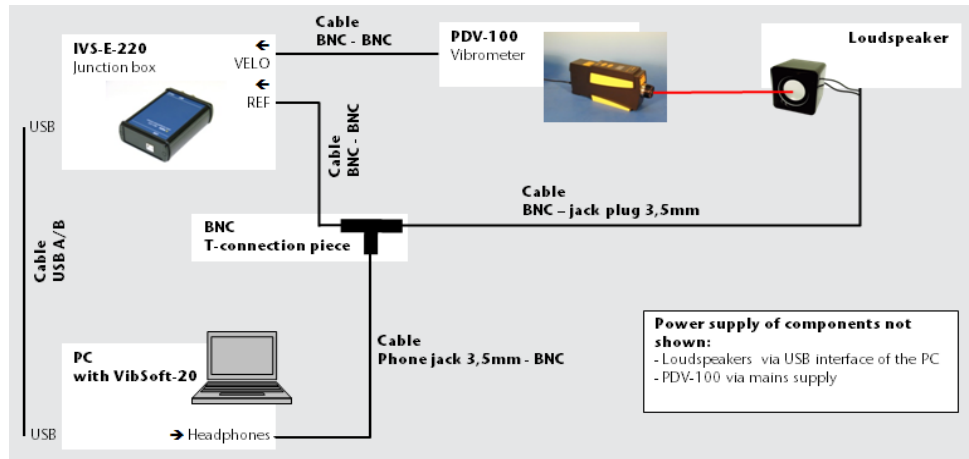

Figure 4.3: Connection diagram for experimental setup without function generator

#### Fine-tuning the experimental setup

To fine-tune the experimental setup, please proceed as follows:

1. Set the Laser Doppler Vibrometer up in such a way that the laser beam hits the middle of the loudspeaker membrane.
2. Turn the loudspeaker so that the laser beam hits the loudspeaker membrane approximately at right angles.
3. Focus the laser beam on the loudspeaker membrane by rotating the focusing ring on the vibrometer. An optimal focus is characterized by a small sample point and a maximum signal level at the signal level display of the vibrometer.

## 4.3 Carrying Out the Experiment

### 4.3.1 Measuring the Loudspeaker Frequency Response

To determine the frequency response of the loudspeaker, the frequency response is excited broadband with white noise.

#### Preliminary considerations

Laser Doppler Vibrometers measure the speed of movement of objects. The signal quantities vibration displacement and vibration acceleration are determined if required by numeric integration or derivation in the software VibSoft-20.

1. How are the signal quantities vibration displacement, vibrational velocity and vibrational acceleration linked to each other? Formulate the relationship as an equation! What effect does the relationship you have determined have qualitatively on the frequency spectra of the 3 signal quantities?
2. Which of the 3 signal quantities (vibration displacement, vibrational velocity or vibrational acceleration) do you need to use to evaluate the acoustic properties of the loudspeaker?
3. Assuming an optimal loudspeaker, which frequency response do you expect (progress of the measured quantity selected in section 2 with different frequencies)? At which frequency should resonances of the loudspeaker vibration occur?
4. Which parameters (velocity measurement range, high pass filter, low pass filter) of the laser vibrometer are meaningful when measuring the frequency response?

#### Result 1

If the vibration displacement is described as a harmonic sinusoidal vibration

$$s(t) = A \cdot \sin(2\pi \cdot f \cdot t) \quad \text{Equation 4.1}$$

with A as the vibration displacement amplitude and f as the vibration frequency, then the vibrational velocity and vibrational acceleration can be derived as the first and second derivation of the vibration displacement over time, as described in the following:

$$v(t) = A \cdot 2\pi \cdot f \cdot \cos(2\pi \cdot f \cdot t) \quad \text{Equation 4.2}$$

$$a(t) = A \cdot 4\pi^2 \cdot f^2 \cdot \sin(2\pi \cdot f \cdot t) \quad \text{Equation 4.3}$$

The signal amplitudes of the vibration displacement  $s(t)$ , the vibrational velocity  $v(t)$  and the vibrational acceleration  $a(t)$  are linked to each through the factor  $2\pi f$ . With the same vibration displacement amplitude and different frequencies, the vibrational velocity and vibration acceleration are greater for higher frequencies than for low frequencies. For the frequency response of the three signal quantities, it is expected that the maximum values of the vibration displacement occur at low frequencies, in contrast the maximum values of the vibrational acceleration occur at higher frequencies.

#### 4 Experiment Loudspeaker Characterization

**Result 2** The physical quantity for technical evaluation of loudspeakers is the acoustic pressure as a measure of the volume. The acoustic pressure is directly connected to the vibrational velocity. The measured quantity relevant for evaluating the loudspeaker is therefore the vibrational velocity.

**Result 3** It is expected of a loudspeaker that all frequencies are transmitted with the same sensitivity. Here, not only the technical transmission of the acoustic signals plays a role, but the acoustic sensitivity of people does too. An optimal loudspeaker therefore plays back all frequencies at the same volume as perceived by the listener. As a general rule, there is a 1:1 relationship between the acoustic pressure level  $L_p$  and the volume perceived. The relationship however is not always linear but depends on the pitch and the absolute acoustic pressure of the sound. For a uniform evaluation of the sound sources, the relationship was linearized in connection with the standard IEC/DIN 651. The quantity to be used according to the standard to evaluate the loudspeaker is the evaluated acoustic pressure level  $L_{AF}$  that is given in the pseudo unit dB(A). The ideal loudspeaker exhibits a horizontal frequency range of the evaluated acoustic pressure level  $L_{AF}$  across the entire acoustic frequency range.

**Result 4** It is difficult to estimate the vibrational velocity of the loudspeaker membrane. Thus the largest measurement range of  $500 \frac{mm}{s} / \sqrt{V}$  is selected. As the transmission function of the loudspeaker is to be measured as purely as possible across the entire acoustic frequency range, all filters need to be deactivated:

Low pass filter: 22 kHz

High pass filter: N

On the vibrometer, set the parameters selected under Result 4!



### 4.3.1.1 Configuring the Software

To measure the loudspeaker frequency response, the frequency response is excited with white noise. Get information from Chapter Excitation Signals in the VibSoft theory manual on advantageous software settings for this excitation signal.

To make changes to the measurement parameters, click **A/D** in the toolbar of the application window. The dialog Acquisition Settings appears.

#### General

1. Display the page General.

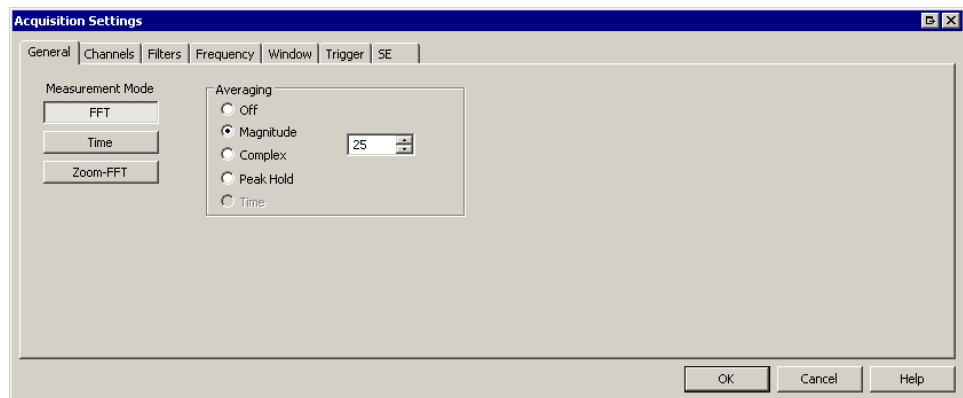

Figure 4.4: Dialog Acquisition Settings, page General

2. Select FFT as the Measurement mode as well as Amplitude for Averaging and set the number of averages to 25.

#### Channels

3. Display the page Channels.

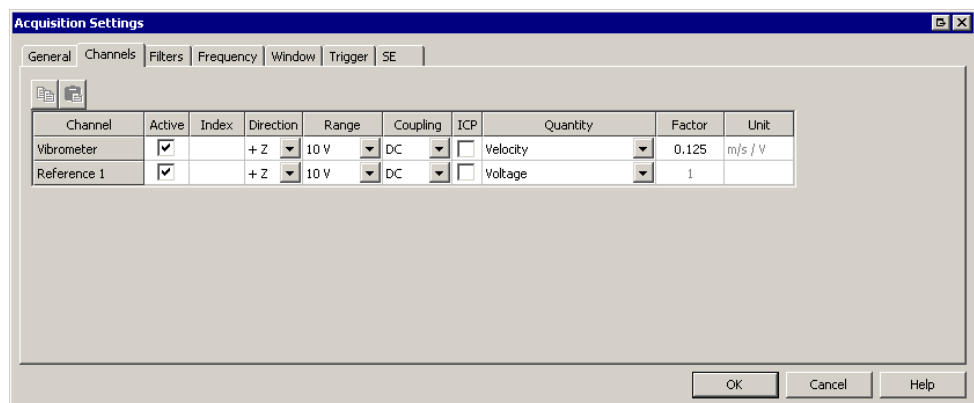

Figure 4.5: Dialog Acquisition Settings, page Channels

4. In the lines Vibrometer and Reference 1, mark the check box Active and deactivate the check box ICP for both channels.
5. For the channel Vibrometer select Velocity in the list Quantity and the Factor  $0.125 \frac{\text{mm}}{\text{s}}/\text{V}$ .

#### 4 Experiment Loudspeaker Characterization

6. For the channel Reference 1, select Voltage in the list Quantity and the Factor 1.
7. In the line Reference 1, deactivate the check box Active (refer to FIGURE 4.5).
8. Comment:  
To select calibration factors for other velocity measurement ranges selected on the vibrometer, refer to SECTION 3.3.2.1.

#### Filters

9. Display the page Filters.

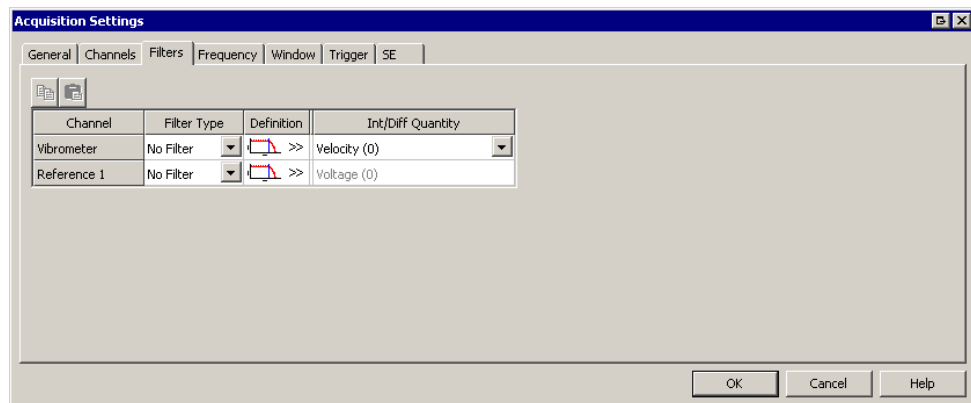

Figure 4.6: Dialog Acquisition Settings, page Filters

10. Deactivate the filters for both channels (refer to FIGURE 4.6).

#### Frequency

11. Display the page Frequency.

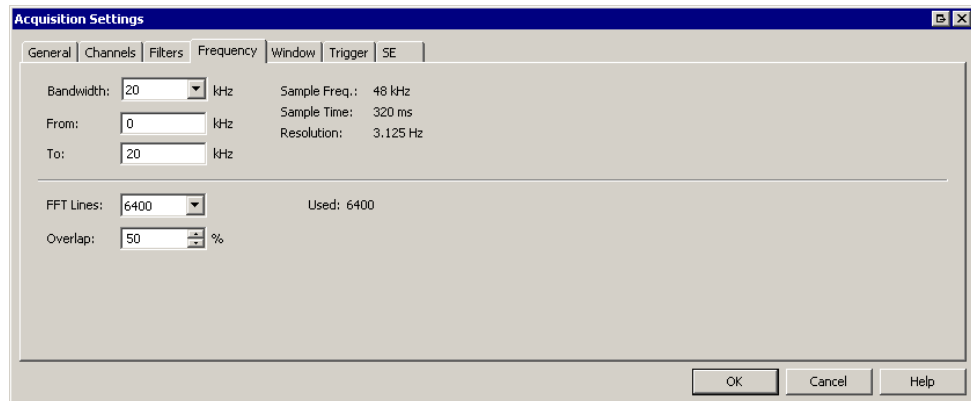

Figure 4.7: Dialog Acquisition Settings, page Frequency

12. Set the parameters for frequency measurement as shown in FIGURE 4.7.  
The frequency spectrum is measured from 0Hz to 20kHz, i.e. the entire acoustic frequency range with a resolution of 6400 FFT lines. The overlap of the individual measurements used for averaging is 50%.

**Window**

13. Display the page Window.

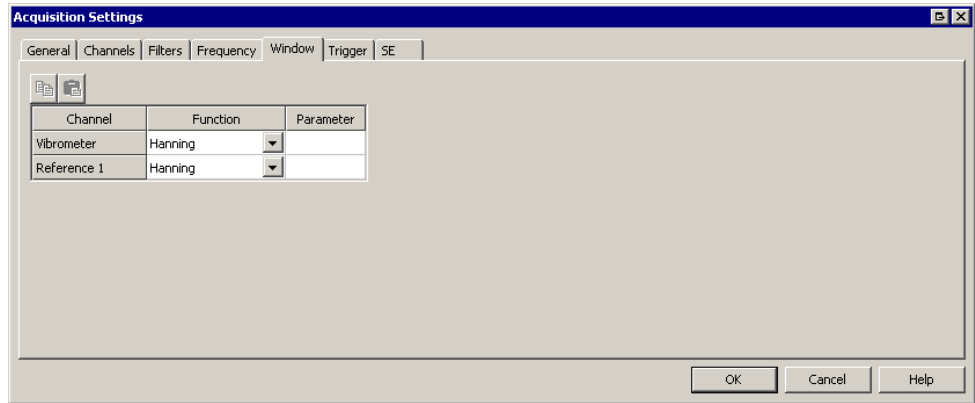

Figure 4.8: Dialog Acquisition Settings, page Window

14. Select Hanning as the function for both channels (refer also to FIGURE 4.8).

**Trigger**

15. Display the page Trigger.

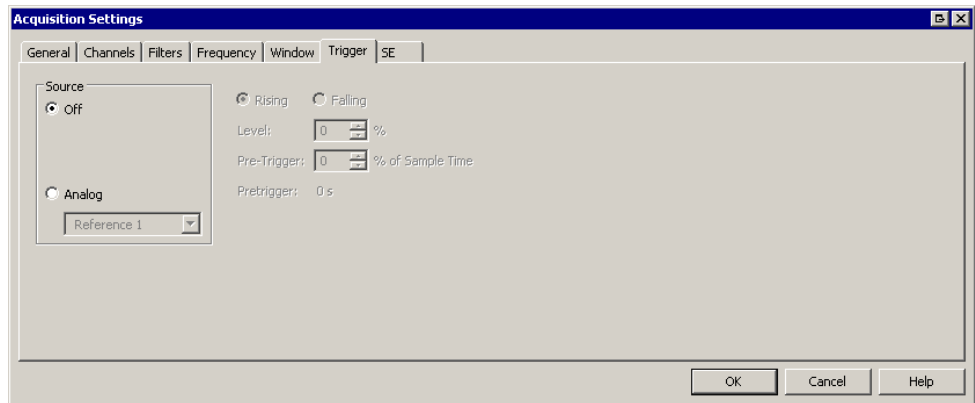

Figure 4.9: Dialog Acquisition Settings, page Trigger

16. Select Off as the source, as the measurement is being started by hand (refer also to FIGURE 4.9).

**Signal Enhancement**

17. Show the page SE (Signal Enhancement).

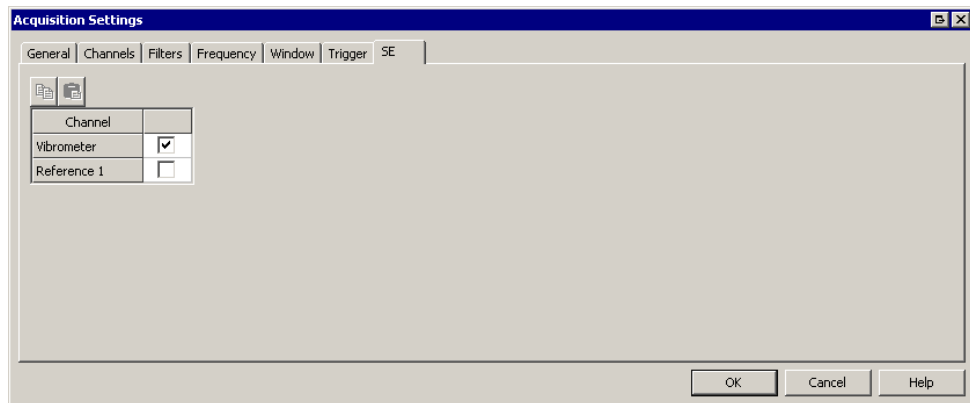







Figure 4.10: Dialog Acquisition Settings, page SE

18. Activate Signal Enhancement for the vibrometer channel (refer also to FIGURE 4.10).

**4.3.1.2 Making Measurements**

To make the measurement, please proceed as follows:

1. Set the volume regulator on the back of the loudspeaker to an average volume (volume regulator pointing vertically upwards).
2. Excite the loudspeaker with white noise. If you are working with the wav files supplied, use the file Signal\_Noise\_20000Hz\_0dB.wav.
3. Start an individual measurement. To do so, click  in the toolbar of the application window.
4. Select the following settings to display the measurement signal:  
 Domain  : FFT; Channel  : Vib & Ref1; Signal  : H1  
 Displacement/Voltage; Display Type  : Amplitude
5. Switch between the signals H1 Displacement/Voltage, H1 Velocity/Voltage and H1 Acceleration/Voltage and compare the frequency spectra with the assumptions made under SECTION 4.3.1.
6. With the aid of the cursor, for two discrete frequencies, determine the relationship between vibration displacement, vibrational velocity as well as vibration frequency and check whether the relationship derived in SECTION 4.3.1 is confirmed by  $2\pi f$ .

**Result**

The frequency response function for vibration displacement, vibrational velocity and vibrational acceleration is shown in FIGURE 4.11 to FIGURE 4.13.

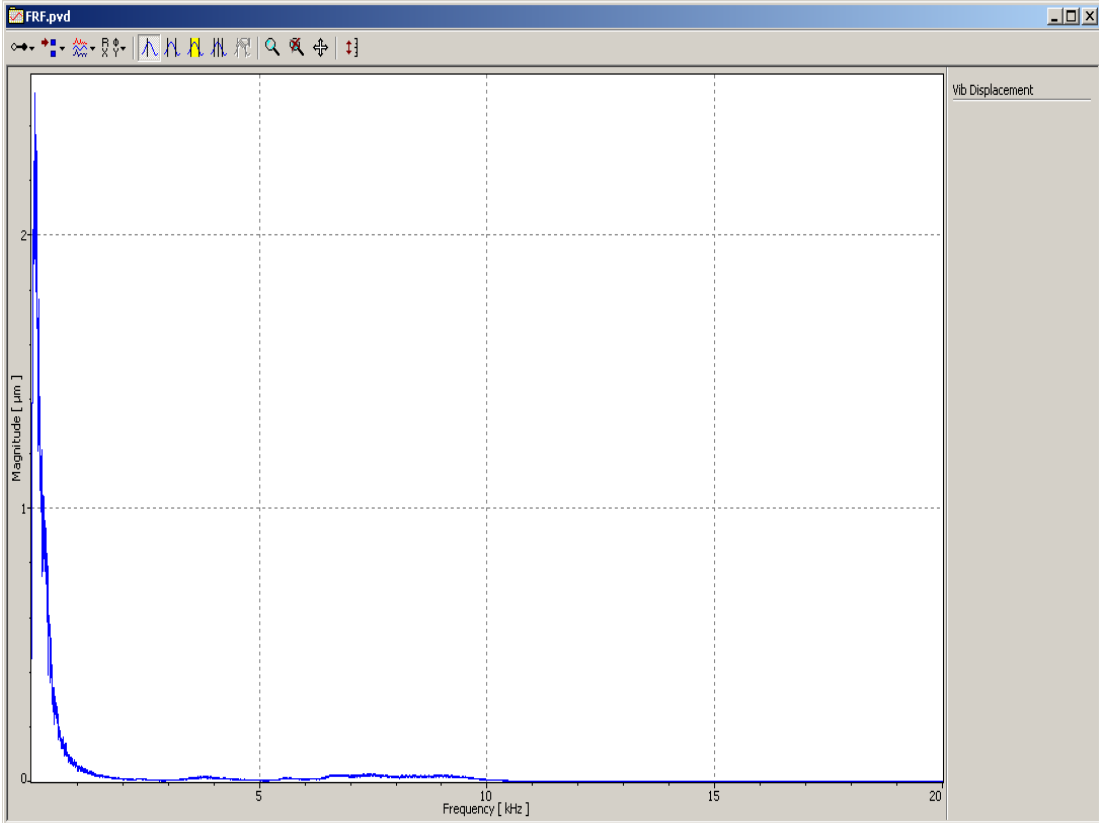

Figure 4.11: Frequency response function of the vibration displacement

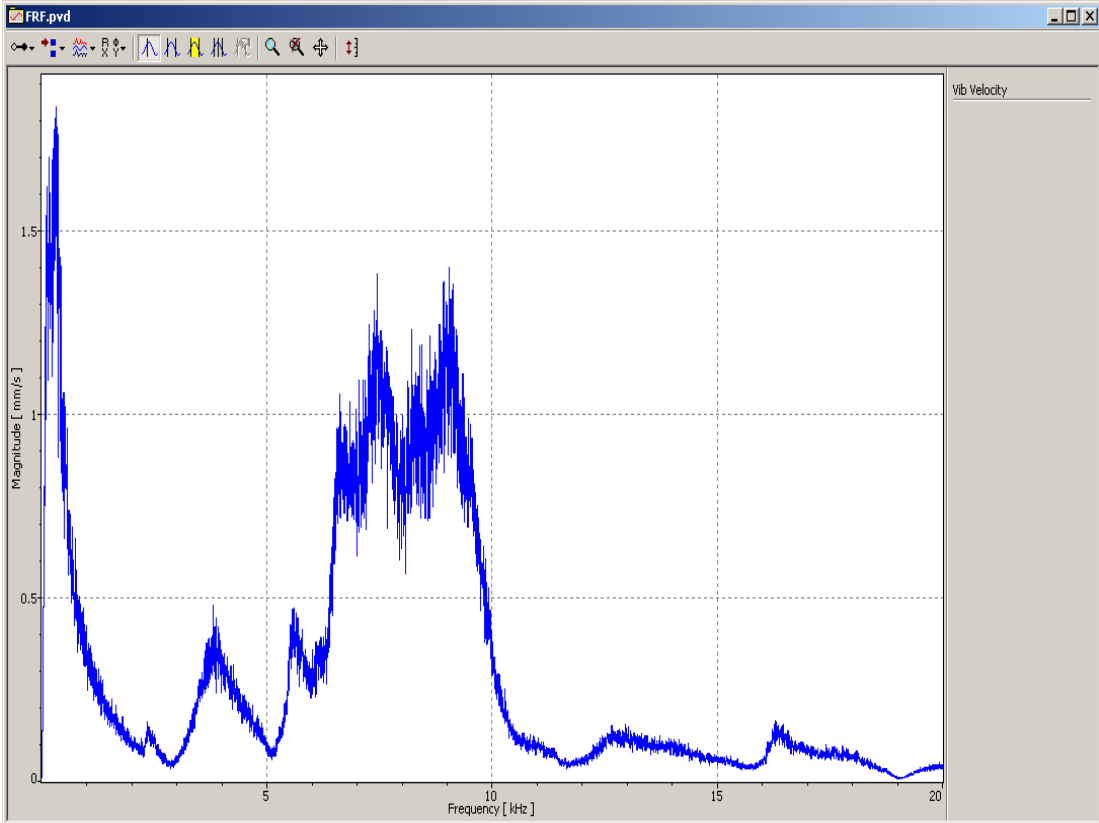

Figure 4.12: Frequency response function of the vibrational velocity

#### 4 Experiment Loudspeaker Characterization

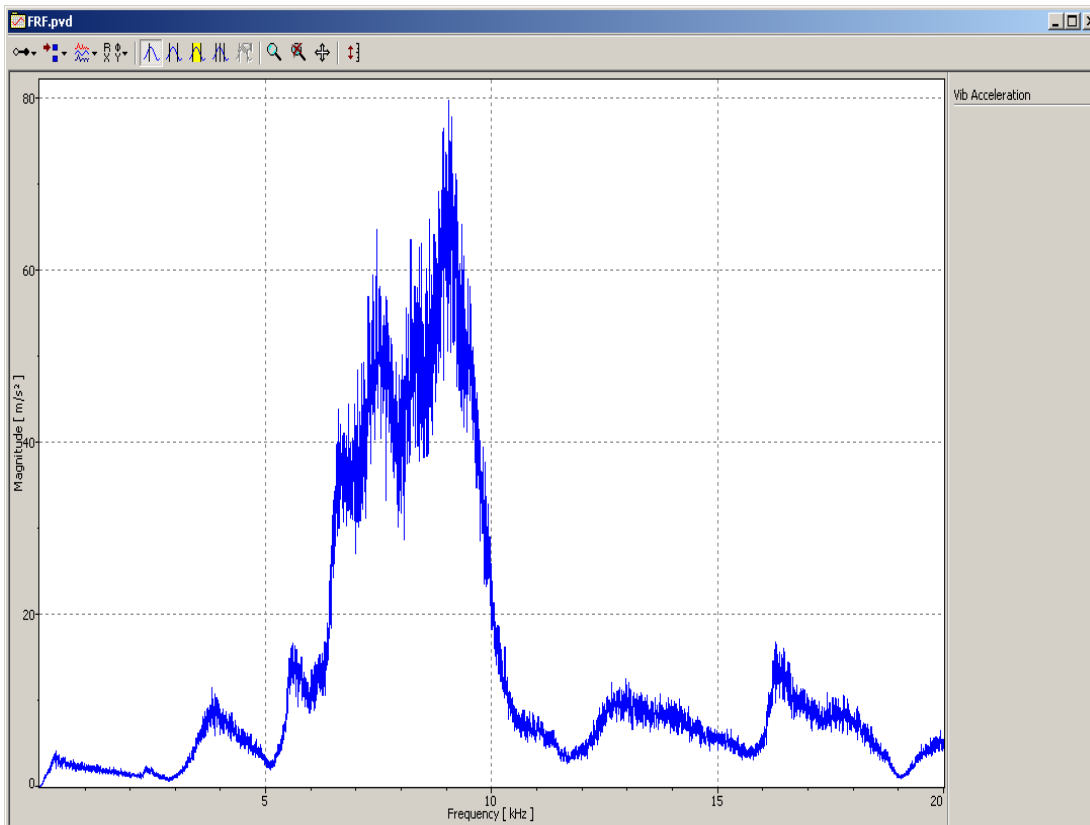



Figure 4.13: Frequency response function of the vibrational acceleration

To analyze the evaluated acoustic pressure and thus the technical quality of the loudspeaker, select the following settings:

Domain  : FFT

Channel  : Vib & Ref1

Signal  : H1 Velocity/Voltage

Display type  : Amplitude [dB(A)]

The result is shown in FIGURE 4.14.

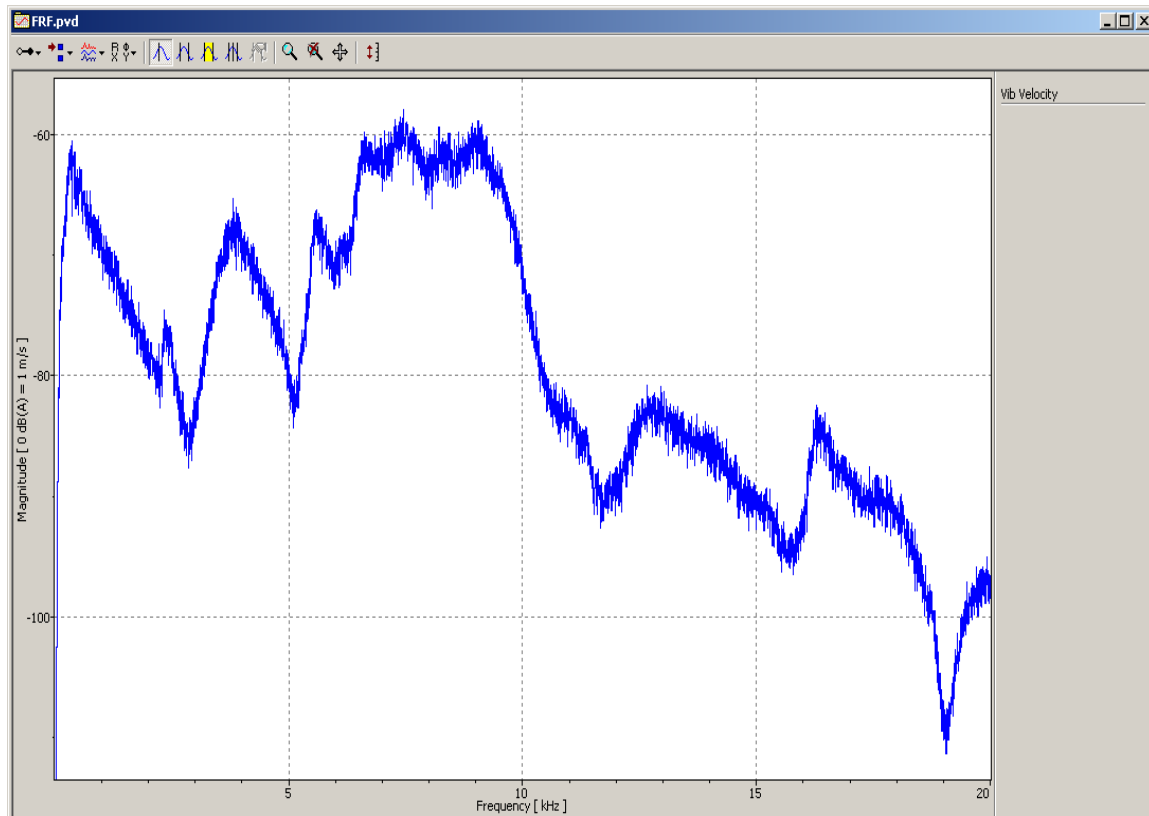

Figure 4.14: A-evaluated acoustic pressure level of the loudspeaker

**Result** Significant nonlinearities can be identified in the frequency response. In the relevant frequency range up to 10 kHz these amount to approx. 20 dB(A) which can already be perceived by a trained sense of hearing.





#### 4.3.2 Examining the Deflection Shapes of the Loudspeaker

From vibration theory it is known that resonant frequencies are associated with characteristic deflection shapes. In SECTION 4.3.1 it was ascertained that the frequency response function shows characteristic frequencies which are transmitted more strongly than others. With exclusive excitation of the loudspeaker with these superior frequencies, it should be possible to determine characteristic deflection shapes.

When analyzing the deflection shapes, it is advantageous to mount loudspeaker or vibrometer on a linear adjuster which can be used to approach the positions at a distance of approx. 1 mm. Alternatively, there is the option of moving the loudspeaker manually relative to the laser beam, whereby the deflection shape of the loudspeaker membrane can be qualitatively acquired, however a quantitative analysis of the measurement values is not possible.

### 4.3.2.1 Identifying the Characteristic Frequencies

The frequency response measured depends on the concrete sample point on the loudspeaker membrane. In particular, in the frequency range from 7 kHz to 10 kHz, signal amplitudes can be identified at different frequencies at various sample points on the loudspeaker. For this reason, in the first step the frequency responses are recorded at several sample points across the full width of the loudspeaker to identify possible characteristic frequencies.





1. Open the dialog Acquisition Settings, display the page General and mark No Averaging.
2. Select the following settings to display the measurement signal:  
Domain  : FFT; Channel  : Vib & Ref1; Signal  : H1 Velocity/  
Voltage; Display Type  : Amplitude
3. Excite the loudspeaker with white noise and start a continuous measurement. To do so, click  in the toolbar of the application window.  
-If you are working with the wav-files supplied, use the file Signal\_Noise\_20000Hz\_0dB.wav.
4. Scan from the middle of the loudspeaker in increments of 1...2 mm until the edge of the loudspeaker and make a note of significant frequencies.

#### Example / Guideline values

For an examined individual loudspeaker, the following characteristic frequencies were identified: (approx. 300 Hz, approx. 3800 Hz, approx. 7600 Hz, approx. 8400 Hz, approx. 9050 Hz).

### 4.3.2.2 Determining the Deflection Shapes of the Loudspeaker

To determine the deflection shape of the loudspeaker, please proceed as follows:

1. Open the dialog Acquisition Settings and display the page General.
2. Select FFT as the Measurement mode as well as Amplitude for Averaging and set the number of averages to 10.
3. Select the following settings to display the measurement signal:  
Domain  : FFT; Channel  : Vib; Signal  : Velocity; Display  
Type  : Amplitude  
As an alternative, it is possible to carry out an analysis in the domain  : Time.
4. Select one of the frequencies identified in SECTION 4.3.2.1 and excite the loudspeaker with an appropriate sinusoidal signal.
5. Aim the laser beam at a position at the edge of the loudspeaker membrane.



6. Start an individual measurement. To do so, click  in the toolbar of the application window.
7. Record the measurement position and signal amplitude.
8. Select the next measurement position on the loudspeaker approx. 1 mm away.
9. Repeat steps 5 to 7 until you have acquired the full width of the loudspeaker completely.

Repeat the process for all frequencies identified in SECTION 4.3.2.1. Evaluate the measurement results graphically so that the deflection shapes are visible. In FIGURE 4.15 you will see examples of the results for 3 frequencies of an individual loudspeaker that has been examined.

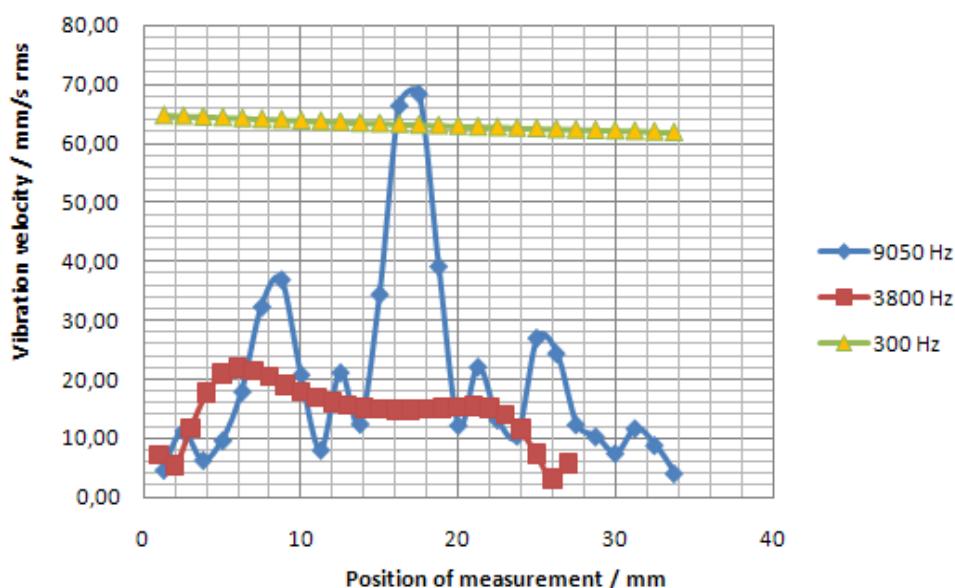

Figure 4.15: Vibrational velocities across the full width of the loudspeaker upon excitation with sinusoidal signals

### Comment

In the case of measurements across a loudspeaker diagonal, there is of course no guarantee that the deflection shape of the loudspeaker membrane is axially symmetric. It is possible in principle that, apart from radial deflection shapes, there are also those which progress around the circumference of the loudspeaker. When examining several individual loudspeakers, all clearly defined deflection shapes were virtually axially symmetric.

## 4 Experiment Loudspeaker Characterization

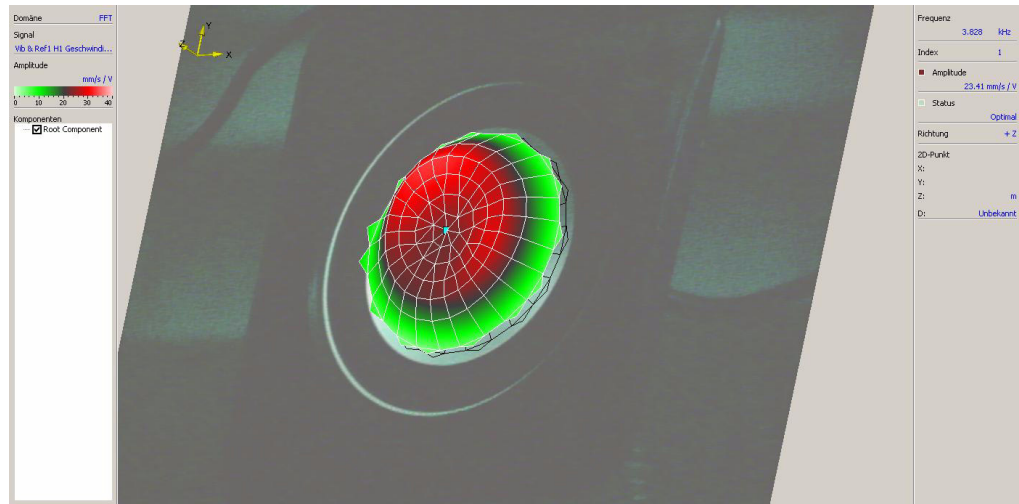





Figure 4.16: Deflection shape of the loudspeaker membrane at 3800Hz

In FIGURE 4.16 the deflection shape of the loudspeaker at 3800Hz measured with a scanning Laser Doppler Vibrometer is shown as an example. The deflection shape shows good correlation with the previously determined results. You will find further material on displaying the deflection shapes of the loudspeaker graphically at [www.MyPolytec.net](http://www.MyPolytec.net).

### 4.3.3 Examining the Linearity of the Loudspeaker

When evaluating the acoustic properties of the loudspeaker, apart from the frequency response at a volume level, the constancy (linearity) of the frequency response with regards to different volumes is of great importance. For the examination, please proceed as follows:

1. Aim the laser beam at the center of the loudspeaker.
2. Configure the software as described in SECTION 4.3.1.
3. Select the following settings to display the measurement signal:

Domain  : FFT; Channel  : Vib & Ref1; Signal  : H1 Velocity/  
Voltage; Display Type  : Amplitude

4. Excite the loudspeaker consecutively with white noise at different signal levels (volumes).
5. Start an individual measurement respectively.
6. Save all the individual measurements.

#### Note:

- Keep the sample point constant for all measurements.
- Keep the setting of the volume control on the loudspeaker constant for all measurements.

**Analysis in the signal processor**

To analyze the data in the signal processor, please proceed as follows:

1. In VibSoft-20, open a new window for the signal processor. To do so, select File > New > Signal processor.
2. In VibSoft-20, activate the window for the first data file.
3. Click the analyzer with the right mouse button and select Copy in the context menu. The dialog Copy appears.
4. Select signal processor and click OK. The data will be copied.
5. Activate the window of the signal processor. Add the measurement data you have copied into the field A1. To do so, click the field A1 with the right mouse button and select Insert in the context menu.
6. Repeat steps 2 to 5 for the other data files. However, add these in the fields A2, A3 etc.
7. In the signal processor, mark all fields which are to be shown together graphically.
8. As your Display Type, select  in the signal processor Amplitude dB(A).

For information on working with the signal processor, please also refer to SECTION 3.3.4.

**View Style in the signal processor**

In FIGURE 4.17 the amplitude frequency response of the loudspeaker is shown at 5 different volume levels. In the critical lower frequency range up to 8 kHz a very good linearity. Above 8 kHz, deviations of 3 dB are visible which can be classified as being uncritical in this order of magnitude.

#### 4 Experiment Loudspeaker Characterization

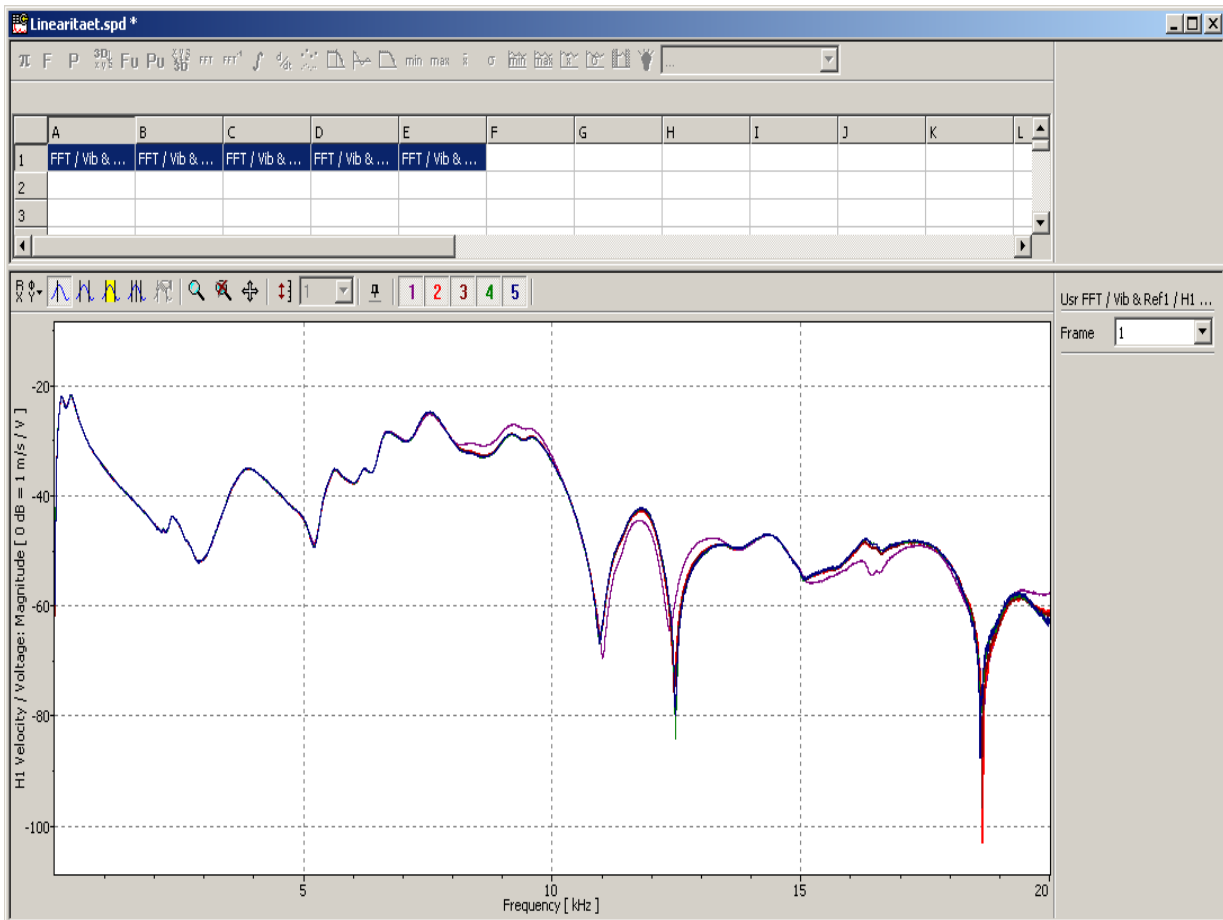

Figure 4.17: Linearity of the frequency response at different levels

## 5 Demonstration Experiment Optical Microphone

### 5.1 Basics

Acoustic signals are longitudinal vibrations in the shape of air pressure fluctuations. A loudspeaker generates these through membrane vibrations. If a loudspeaker membrane is sampled with the Laser Doppler Vibrometer and the voltage signal in turn is emitted as an acoustic signal, then the Laser Doppler Vibrometer works as an optical microphone.

### 5.2 Experimental Setup



---

#### WARNING!

**Danger from laser light!** Connecting the mains supply to the PDV-100 switches the laser on. The laser in the PDV-100 belongs to Laser Class 2 and is therefore safe for the user as a general rule. Despite this, looking directly into the laser should be avoided. Also avoid looking at direct reflections from reflective surfaces (e.g. the loudspeaker membrane). For further information, please refer to the PDV-100 manual.

---



---

#### WARNING!

**Danger from sound intensity level!** The test material allows headphones to be connected to the BNC signal output on the PDV-100. To avoid causing damage to your hearing, make sure that the volume regulator integrated into the headphone cable is set to minimum volume. Only headphones that have been approved by Polytec may be connected to the PDV-100.

---

Set up the experiment as shown in FIGURE 5.1. The distance between PDV-100 and the loudspeaker can be freely selected in the range of the specified stand-off distance for the PDV-100 (approx. 10 cm... 30 m). For demonstration purposes in front of large groups, the headphones can be replaced by an active loudspeaker.

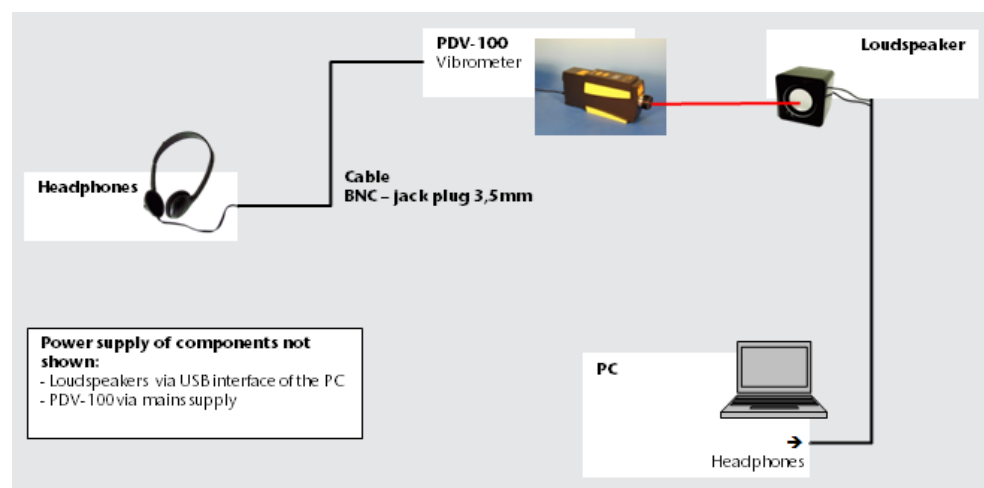

Figure 5.1: Connection diagram for experimental setup as an optical microphone

### 5.3 Carrying Out the Experiment

For a measurement, please proceed as follows:

1. Set the following parameters on the PDV-100:

Velocity measurement range **Velo**:  $500 \frac{\text{mm}}{\text{s}}$

Low pass filter **LP**: 22 kHz

High pass filter **HP**: N

2. Focus the laser beam on the loudspeaker membrane by turning the focusing ring of the PDV-100. Place a sound source on the PC.
3. Use the headphones to listen to the signal received.
4. Check the robustness of the transmission by defocusing the laser beam and introducing transparent media, such as a glass plate into the path of the beam.
5. How does the transmission quality change?

## 6 Literature Recommendations

### **Metrology: Vibration measurement**

Barber, A.: Handbook of noise and vibration control, Elsevier Science Publishers Ltd., 1992, ISBN 1-85617-079-9

De Silva, C.W.: Vibration, Fundamentals and Practice, CRC Press LLC, 2000, ISBN 0-8493-1808-4

### **Metrology: Laser Doppler Vibrometry**

Drain, L. E.: The Laser Doppler Technique, John Wiley & Son Ltd., New York, 1980

Braun, S.G., Ewins, D.J., Rao, S.S.: Encyclopedia of Vibration, Academic Press, 2002, ISBN 0-12-227085-1

Lewin, A., Mohr, F., Selbach, H.: Heterodyn-Interferometer zur Vibrationsanalyse, Technisches Messen, 57: 315-362, 1990. (German language)

### **Engineering Mechanics: Vibrations**

Brommundt, E., Sachau, D.: Schwingungslehre mit Maschinendynamik, Teubner Verlag / GWV Fachverlage GmbH, Wiesbaden, 2008, ISBN 978-3-8351-0151-7 (German language)

Klotter, K.: Technische Schwingungslehre, First Vol.: Einfache Schwinger, Teil A: Lineare Schwingungen, Springer-Verlag Berlin Heidelberg New York, 1978, ISBN 3-540-08673-0 (German language)

Bottega, W.J.: Engineering Vibrations, CRC Press, 2006, ISBN 0-8493-3420-9

Benaroya, H.: Mechanical Vibration, Analysis, Uncertainties and Control, Marcel Dekker Inc., 2004, ISBN 0-8247-5380-1

### **Engineering Mechanics: Basics on motion of a rolling disk (refer also to links at [www.MyPolytec.net](http://www.MyPolytec.net))**

Leine, R.I.: Experimental and theoretical investigation of the energy dissipation of a rolling disk during its final stage of motion, Arch Appl. Mech., DOI 10.1007/s00419-008-0278-6, Dec., 12, 2008

Diaz, V.A., Cendra, H: The Lagrange-D'Alembert-Poincare Equations and Integrability for the Euler's Disk, Regul. Chaotic Dyn., 12 (1): 56-67, 2007

Batista, M.: Integrability of the motion of a rolling disk of finite thickness on a rough plane, International Journal of Non-Linear Mechanics, Vol. 41, Issues 6-7: 850-859, July-Sept, 2006

Saje, M., Zupan, D.: The Rattling of Euler's Disk, Multidiscipline Modeling in Materials and Structures, Vol. 2, No.1: 49-66(18), 2006

Villanueva, R., Epstein, M.: Vibrations of Euler's Disk, Phys. Rev. E71, 066609, 2005

Le Saux, C., Leine, R.I., Glocker, C.: Dynamics of a Rolling Disk in the Presence of Dry Friction, J. Nonlinear Sci., Vol. 15: 27-61, 2005

Caps, H., Dorbolo, S., Ponte, S., Croisier, H., Vandewalle, N.: Rolling and slipping motion of Euler's disk, Physical Review, E 69, 056610 (6), 2004

Stanislavsky, A., Weron, K.: Nonlinear oscillations in the rolling motion of Euler's disk, Physica D: Nonlinear Phenomena, Vol. 156, Issue 3-4: 247-259, 08/2001

Bildsten, L.: Viscous Dissipation for Euler's Disk, Physical Review E, Vol. 66 (5 Pt 2), 056309, Epub., 11/25/2002

McDonald, A.J., McDonald, K.T.: The Rolling Motion of a Disk on a Horizontal Plane.

Ruina, A.: Rolling and Sliding of spinning things: Euler's Disk, Jellett's Egg and Moffatt's Nature, 05/08/2002, Cornell

Kessler P., O'Reilly, O.M.: The Ringing of Euler's Disk, Reg. Chaot. Dyn., 7(1): 49-60, 2002

Easwar, K., Rouyer, F., Menon, N.: Speeding to a stop: The finite-time of a spinning disk, Physical Review, E 66, 045102(R), 2002, The American Physical Society

**Signal processing: Sampling conditions, Fast Fourier Analysis (FFT)**

Ohm, J.-R., Lüke, H.D.: Signalübertragung, Springer-Verlag Berlin Heidelberg New York, 2007, ISBN 978-3-540-69256-0 (German language)

Haykin, S., Van Veen, B.: Signals and Systems, John Wiley & Sons Inc., 2003, ISBN 0-471-16474-7

Oppenheim, A.V., Willsky, A.S.: Signals and Systems, Prentice Hall, 1996, ISBN 978-0138147570



## Polytec Europe

### Germany (DE)

Polytec GmbH  
Headquarters  
Polytec-Platz 1-7  
76337 Waldbronn

Tel.: +49 7243 604-0  
Fax: +49 7243 69944  
E-mail: [info@polytec.de](mailto:info@polytec.de)  
Internet: <http://www.polytec.de>

### Germany (DE)

Polytec GmbH  
Sales and Consulting Office Berlin  
Schwarzschildstraße 1  
12489 Berlin

Tel.: +49 30 6392-51 40  
Fax: +49 30 6392-51 41  
E-mail: [polytecberlin@polytec.de](mailto:polytecberlin@polytec.de)  
Internet: <http://www.polytec.de>

### France (FR)

Polytec France S.A.S.  
TECHNOSUD II, Bâtiment A  
99, Rue Pierre Semard  
92320 Châtillon

Tel.: +33 1 49 65 69-00  
Fax: +33 1 57 19 59 60  
E-mail: [info@polytec.fr](mailto:info@polytec.fr)  
Internet: <http://www.polytec.fr>

### Great Britain (GB)

Polytec Ltd.  
Lambda House  
Batford Mill  
Harpenden, Hertfordshire AL5 5BZ

Tel.: +44 1582 711670  
Fax: +44 1582 712084  
E-mail: [info@polytec-ltd.co.uk](mailto:info@polytec-ltd.co.uk)  
Internet: <http://www.polytec-ltd.co.uk>

## Polytec Worldwide

### ASEAN Countries

Polytec South-East Asia Pte. Ltd.  
Blk 4010, Ang Mo Kio Ave 10  
#06-06 TechPlace I  
Singapore 569626

Tel.: +65 64510886  
Fax: +65 64510822  
E-mail: [info@polytec-sea.com](mailto:info@polytec-sea.com)  
Internet: <http://www.polytec-sea.com>

### China (CN)

Polytec China Ltd.  
Room 1026, Hanwei Plaza,  
No.7 Guanghua Road, Chaoyang District  
Peking 100004

Tel.: +86 10 6568 2591  
Fax: +86 10 6568 8291  
E-mail: [info-cn@polytec.com](mailto:info-cn@polytec.com)  
Internet: <http://www.polytec.com/cn>

### Japan (JP)

Polytec Japan  
13th floor, Arena Tower,  
3-1-9 Shinyokohama, Kohoku-ku  
Yokohama-shi, 222-0033 Kanagawa

Tel.: +81 45 478-6980  
Fax: +81 45 478-6981  
E-mail: [info@polytec.co.jp](mailto:info@polytec.co.jp)  
Internet: <http://www.polytec.co.jp>

### USA West

Polytec, Inc.  
North American Headquarters  
16400 Bake Parkway, Suites 150 & 200  
Irvine, CA 92618

Tel.: +1 949 943-3033  
Fax: +1 949 679-0463  
E-mail: [info@polytec.com](mailto:info@polytec.com)  
Internet: <http://www.polytec.com/us>

### USA Central

Polytec, Inc.  
Central Office  
1046 Baker Road  
Dexter, MI 48130

Tel.: +1 734 253-9428  
Fax: +1 734 424-9304  
E-mail: [info-central@polytec.com](mailto:info-central@polytec.com)  
Internet: <http://www.polytec.com/us>

### USA East

Polytec, Inc.  
East Coast Office  
25 South Street, Suite A  
Hopkinton, MA 01748

Tel.: +1 508 417-1040  
Fax: +1 508 281-4725  
E-mail: [info-east@polytec.com](mailto:info-east@polytec.com)  
Internet: <http://www.polytec.com/us>

