

COHU, INC. Electronics Division

Installation and Operation Instructions

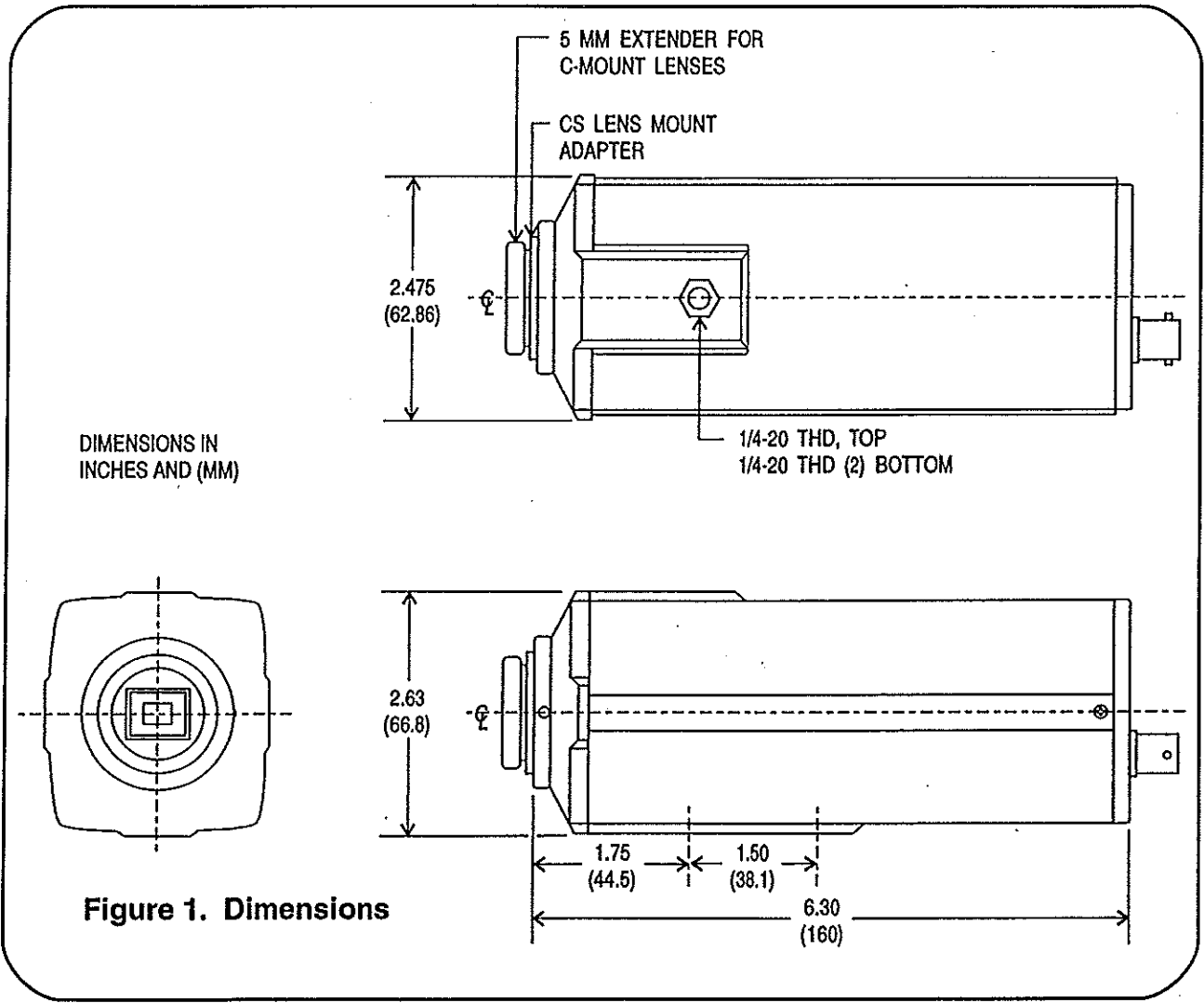

Figure 1. Dimensions

4910 SERIES RS-170 AND CCIR MONOCHROME CCD CAMERAS

3912 CALLE FORTUNADA • SAN DIEGO
PHONE: 858-277-6700 • FAX: 858-277-022



Industries et Systèmes

2, rue Henri Janin 78470 ST REMY LES CHEVREUSE
Tel : 01 30 47 45 86 - Fax : 01 30 47 93 37
info@sacasa.fr - www.sacasa.fr
Les centrales de mesure sur mesure

6X-924(E)

Table 1. Specifications

ELECTRICAL	
Image Area	6.4 x 4.8 mm (corresponding to a 1/2-in. image tube)
Active Picture Elements	RS-170 768 (H) x 494 (V) CCIR 752 (H) x 582 (V)
Imager Type	On chip microlens sensor interline transfer CCD
Cell Size	RS-170 8.4 (H) x 9.8 (V) microns CCIR 8.6 (H) x 8.3 (V) microns
Resolution (TV lines)	RS-170 580 horizontal, 350 vertical CCIR 560 horizontal, 450 vertical
Sensitivity, 2854 K	See table 1a
Electronic Shutter	Eight steps. OFF (1/60, 1/50), 1/125, 1/250, 1/500, 1/1000, 1/2000, 1/4000, 1/10,000 second
Integration	Field (1/60, 1/50) or frame (1/30, 1/25), Internally jumper selectable Controllable period through external input pulse Grab pulse output
Video output	1.0 V p-p, 75 ohm, unbalanced
Gamma	Continuously variable 0.45 to 1.0
Agc	26 dB (variable gain)
Auto Black	Maintains setup level at 7.5±5 IRE if picture contains at least 10% black (jumper selectable on/off)
Signal-to-Noise Ratio	56 dB, gamma 1, gain 0 dB 38 dB, gamma 1, agc maximum gain
Auto Lens	Separate lens video output eliminates agc/auto-iris lens interaction (peak/average adjustable) Lens power output +15 V dc, 35 mA maximum
Sync	Genlock*, revert to variable phase line lock, zero crossing detector Genlock*, revert to crystal* Crystal lock Asynchronous reset Internal clock: 28.6363 MHz RS-170(A) or 28.375 MHz CCIR *Genlock Includes H and V Drive Inputs
Input Power	12 V ac/dc (standard) 24 V ac / 24-28 Vdc optional 115 V ac, 60 Hz (optional on RS-170 models. Wall transformer with cable provides 12 V ac to Camera) 230 V ac, 50 Hz (optional on CCIR models. Wall transformer with cable provides 12 V ac to Camera) 4.2 watts dc power consumption Green LED power indicator (Also serves as electronic iris in-range indicator)
MECHANICAL	
Dimensions	See figure 1
Weight, less lens	520 grams (18.5 oz)
Lens Mount	CS or C mount, 16-mm format CS-mount adapter provided 5-mm extension ring provided for adapting to C-mount lenses
Camera mount	1/4-20 threaded holes top (1) and bottom (2)
ENVIRONMENTAL	
Ambient Temperature Limits	Operating: -20 to 60 °C (-4 to 140 °F) Storage: -30 to 70 °C (-22 to 158 °F)
Relative Humidity	Up to 95%, non-condensing
Vibration	Sine vibration from 10 to 2000 Hz, 5 G peak , all 3 axes, 1/2 hour per axis per MIL-E-54007, paragraph 3.2.24.5.1.2, fig. 2, curve IIIA. Random vibration from 10 to 2000 Hz, 11 G RMS all 3 axes, 1/2 hour per axis. Meets MIL-E-5400T, paragraph 3.2.4.24.5.1.2A, category 6
Shock	Up to 15 g's in any axis under nonoperating conditions, MIL-E-5400T, paragraph 3.2.24.6

NOTE: This equipment has been tested and found to comply with the limits for a Class B digital device, pursuant to part 15 of the FCC rules. These limits are designed to provide reasonable protection against harmful interference in a residential installation. This equipment generates, uses and can radiate radio frequency energy and, if not installed and used in accordance with the instruction manual, may cause harmful interference to radio or television reception, which can be determined by turning the equipment off and on. The user is encouraged to try to correct the interference by one or more of the following measures:

1. Reorient or relocate the receiving antenna.
2. Increase the separation between the equipment and the receiver.

This device complies with part 15 of the FCC Rules. Operation is subject to the following two conditions: (1) This device may not cause harmful interference, and (2) this device must accept any interference received, including interference that may cause undesired operation.

Complies With VDE, 0871, Class B Requirements

Complies with CE CISPR-22, Class B; EN 55022, Class B; EN 50081-1; EN 50082-1

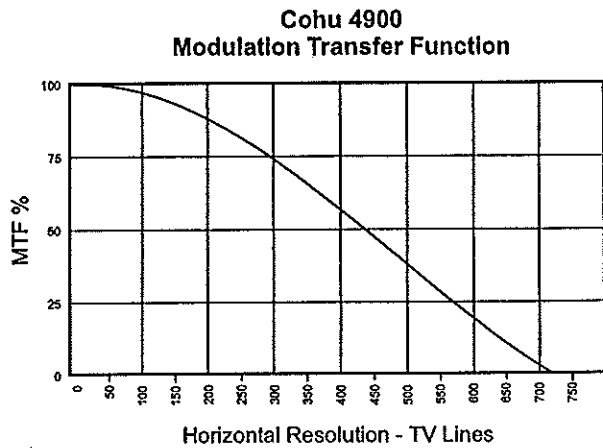
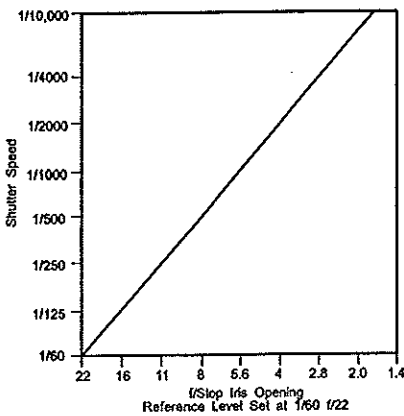
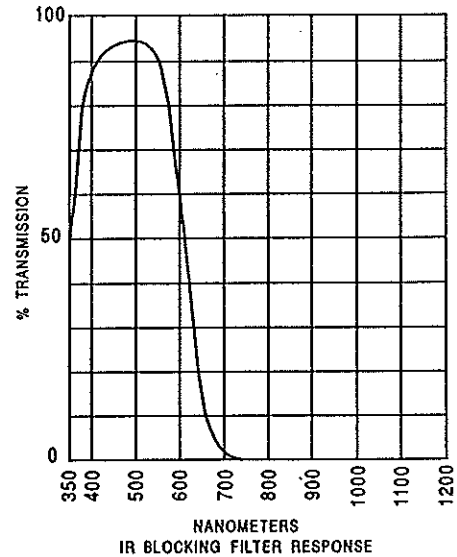
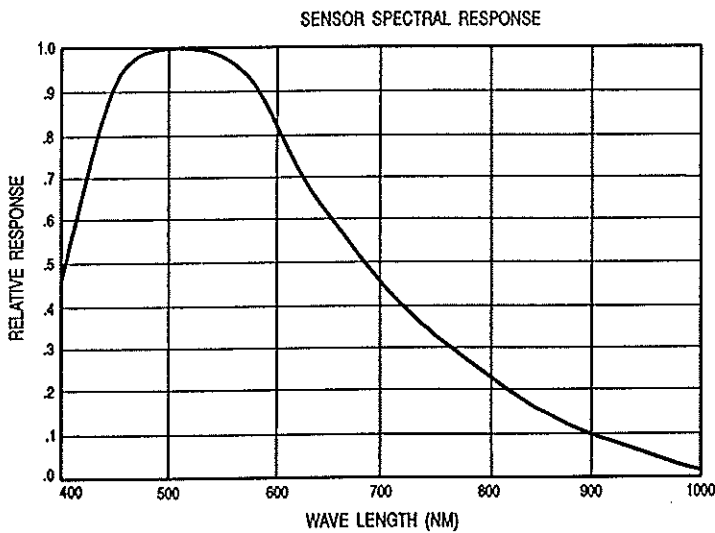
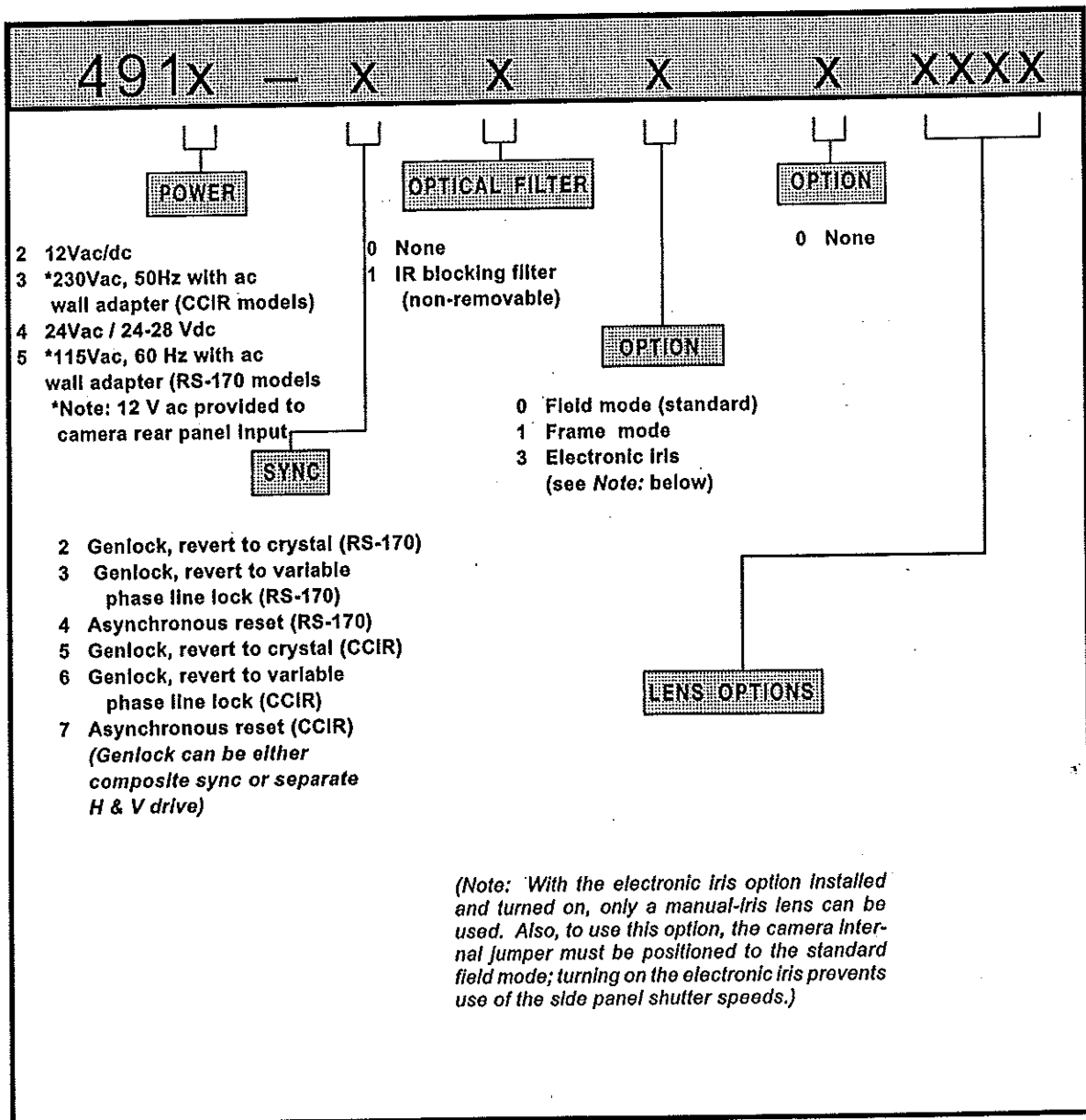

Table 1a. Faceplate Sensitivity

SENSITIVITY	Full Spectrum	With IR Blocking Filter
Full Video, No Agc	0.065 fc (0.65 lux)	0.25 fc (2.5 lux)
80% Video, Agc On	0.002 fc (0.02 lux)	0.01 fc (0.1 lux)
30% Video, Agc On	0.0004 fc (0.004 lux)	0.0015 fc (0.015 lux)

Note: Sensitivity in the non-interlaced frame mode will be one-half the values given in the table

Table 2. Model Number Interpretation



1.0 ELECTRICAL CHARACTERISTICS

The 4910 monochrome Camera uses a 1/2-inch format interline transfer sensor with on-chip micro-lenses. This sensor offers lower dark current, image lag, and blooming than other types of sensors. It has improved dynamic range and spectral characteristics, too. A 1000:1 overload capacity prevents bright incidental light in a scene from deteriorating the video. The agc has a 20-dB range. Auto black can be turned on and off with an internal jumper. See table 1 for a complete listing of specifications.

Field transfer is the normal operating mode but frame transfer can be selected with an internal repositionable jumper. Section 13 describes differences between these two operating modes.

The Camera is available in RS-170 and CCIR versions. See table 2 for a model number interpretation chart.

When an RS-170 version of the Camera operates with internal crystal as the sync reference source, its field rate is 59.94 Hz. This is consistent with RS-170(A) specifications, making the Camera compatible with field and line rates for color systems. When genlocked the Camera operates at whatever field rate the input pulse supplies.

A line-locked RS-170 version of the Camera operates at a 60-Hz field rate; a line-locked CCIR version operates at 50 Hz.

On the rear panel, a screwdriver adjustment for line-lock PHASE provides 180-degree control range. If additional adjustment range is required, the low-voltage ac power input leads to the rear panel can be reversed to provide a 180-degree phase shift.

A side-panel trim plate can be removed to access seven controls and switches.

Electronic shuttering is available to provide stop-action effect for moving scenes. Any one of eight shutter speeds from OFF (1/60, 1/50) to 1/10,000 second can be manually selected by a side-panel switch. (If the electronic iris option is installed it must be turned off before shuttering can be used.)

The electronic iris option allows a manual iris lens to be used in place of an auto-iris lens when viewing scenes with varying levels of light. This option can be switched on and off with a side panel ELECT IRIS switch. When turned on, it produces smooth electronic control of the sensor through an eight-stop light control range—from 1/60 (1/50) to 1/15,000 second. The effect is a range of electronic shuttering of the sensor to control light from the scene much like the control produced by a mechanical auto iris lens. (It should be noted, though, that auto iris lenses have a much wider range of control.)

A SHARPNESS control on the side panel can be adjusted to increase the definition of white/black and black/white transitions in the scene to improve overall appearance in some situations.

Integration is controlled by application of a control pulse input on the rear panel AUX (auxiliary) connector. Two other pins of this connector provide a complementary grab-pulse output.

When internal jumpers are set to the reset (not normal/genlock) mode, the Camera can be asynchronously reset at any time by application of a reset pulse to the AUX connector at pin 6. This initiates a vertical-blanking interval 2.5 microseconds later. Video output from the BNC connector then

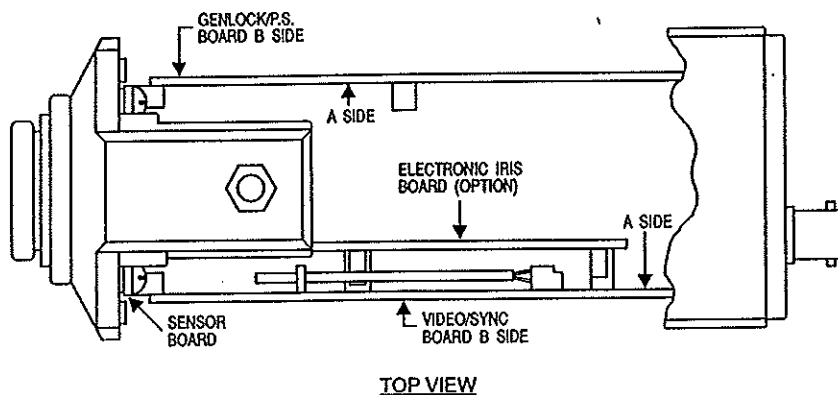

TOP VIEW
Figure 2. Circuit Board Locations

follows the vertical blanking interval, which, for RS-170, is about 1.2 milliseconds (19 to 21 lines) wide. For CCIR, vertical blanking is about 1.6 milliseconds wide (25 lines). If in field mode, this first field of video will most likely be of reduced video level because the reset pulse will have cut the sensor integration period short. Subsequent fields will have a normal video level.

If in frame mode, the first two fields making up an interlaced frame will likely be of reduced (and different) video levels. Subsequent fields making up the frames, though, will be of normal video level.

2.0 MECHANICAL CHARACTERISTICS

See figure 1 for dimensions. Figure 2 shows a top view of the Camera with most of the case cut away. The majority of circuits for the Camera mount on two vertically oriented boards interfacing through hinged connectors to the sensor board at the front. The two boards are secured at the rear by the rear panel.

The optional electronic iris circuit board mounts to two connectors on the video/sync board.

The sensor board mounts to four pads inside the back of the front casting. In front of the sensor board is either a clear glass window or the optional IR blocking filter. The response of this IR filter is shown in the chart accompanying the specifications in table 1.

At the front of this casting is a circular opening threaded to accept a 1.250-32 UNS-2A lens mount adapter. The Camera is supplied with an adapter of a width intended for use directly with CS-type lenses. Using C-mount lenses with this adapter requires that a 5-mm extension ring be installed on the CS-mount adapter. This 5-mm ring is supplied with the Camera.

Opposite each other, at the top and bottom of the front casting, are threaded holes to accept 1/4-20 UNC

mounting bolts. On the bottom of the Camera is a second 1/4-20 threaded hole, 1.5 inch (38.1 mm) to the rear of the front mounting hole in the casting.

The left side of the case has seven holes down its length for access to certain switches and adjustments on the video/sync board. A protective trim strip, held in place by a 2-56 x 1/8 flathead screw, covers these holes when access is not required.

All interconnections with the Camera are made on the rear panel. Table 3 lists part numbers for each of these rear panel connectors and also supplies part numbers for the mating cable connectors. Both the factory part number and a part number from an alternate source are given. This alternate number is either the part number from a manufacturer of that connector or the part number from an alternate supply source.

3.0 POWER REQUIREMENTS

Input power applied to the Camera rear panel connector routes through filtering to a bridge rectifier.

Optoisolators and a flyback transformer in the Camera isolate power input circuits from other circuits in the Camera. This has the same effect as an isolation transformer on the input. The advantage to this isolation is that it allows multiple Cameras to be operated from a single 12 V ac source.

Power input to a standard version of the Camera is 12 V ac or +12 V dc. (A 24-volt option is available.)

With ac input to the rear panel, an RS-170 version must receive 60-Hz power, a CCIR version 50 Hz. Operation in line-lock mode requires that low voltage ac power be applied to the rear panel of the camera.

Power input leads can be applied to either input without regard to polarity. (When setting up operation in the line-lock mode, it is sometimes necessary to

Table 3. Rear Panel Interfacing Connectors

NAME	CAMERA REAR PANEL CONNECTOR		MATING CONNECTOR FOR CABLE	
AUX (J21)	1310373-008 8 Pin Mini DIN Jack	Singatron MDJ-102-8PS	1310373-208 8 Pin Mini DIN Plug	Singatron 62000-8P-S
LENS (J37)	1310375-003 3 Pin Mini DIN Jack	Hosiden TCS7537-01-201	1310373-203 3 Pin Mini DIN Plug	Singatron 62000-3P-S
POWER (J25)	1310378-001	Weco 180-A-111/02	N/A - Requires Stripped Wire Ends	—
VIDEO (J32)	BNC Jack	—	BNC Plug	—

switch the two leads at the rear panel so that the ac input is reversed 180 degrees in phase. See section 11.0.)

If a 12-volt version of the Camera is to be operated from ac line power, optional plug-in wall transformers are available to step down the line voltage to 12 V ac. Both 115-V ac 60-Hz and 230-V ac 50-Hz plug-in wall transformers are available for use with corresponding versions of the Camera.

If the Camera is to operate from a 12-V ac or dc power supply, the supply leads must have a 1/2-amp time-lag fuse in series.

If a Camera with the 24-V ac/dc option is to operate from a 24 volt power supply, the power lead must have a 1/4-amp time-lag fuse in series.

A rear panel lamp indicates when power has been applied to the power input connector. This lamp also serves to indicate when the optional electronic iris circuit is out of range when adjusting the manual iris lens. It can be made to go on and off during the setup.

4.0 EQUIPMENT SUPPLIED

The following list does not include any optional or special-request items. A lens ordered with the Camera will either be installed on or packed with the Camera. The mating lens connector is attached to the cable. Lens mount locking setscrews may be either of two sizes; use the appropriate allen wrench when required.

1. Camera, 4910 series
2. Manual, Installation and Operation — 6X-924(E) [This manual]
3. Adapter, CS-mount
4. Ring, extension, 5 mm, CS-to-C mount
5. Plug, auxiliary connector (for J21 AUX on rear panel)
6. Plug, lens connector (for J37 LENS on rear panel)
7. Allen wrench, L-type, 1/16 inch
8. Allen wrench, L-type, 5/64 inch

5.0 EQUIPMENT REQUIRED BUT NOT SUPPLIED

The first two items are the minimum required to make use of the Camera. These items are listed in the model breakdown for the Camera and are typi-

cally ordered and supplied at the time of purchase. Items 3 and 4 are optional items required to take advantage of Camera capabilities.

The frame grabber is required to use the integration feature. To make use of integration, a start/stop pulse must be supplied to the Camera. The Camera then provides as an output a grab-pulse for use by the frame grabber.

1. Lens, TV type, C-mount or CS-mount (When using the optional electronic iris circuit, a manual iris lens is required)
2. Power supply, ac or dc
3. Sync reset source, asynchronous
4. Frame grabber, with integrate start/stop pulse output and grab-pulse input

6.0 UNPACKING AND RECEIVING INSPECTION

This item was thoroughly tested and carefully packed in the factory. Upon acceptance by the carrier, they assume responsibility for its safe arrival. Should you receive this item in a damaged condition, apparent or concealed, a claim for damage must be made to the carrier. To return the product to the factory for service, please contact the Customer Service Department for a Return Authorization Number.

If a visual inspection shows damage upon receipt of this shipment, it must be noted on the freight bill or express receipt and the notation signed by the carrier's agent. Failure to do this can result in the carrier refusing to honor the claim.

When the damage is not apparent until the unit is unpacked, a claim for concealed damage must be made. Make a mail or phone request to the carrier for inspection immediately upon discovery of the concealed damage. Keep all cartons and packing materials. Since shipping damage is the carrier's responsibility, the carrier will furnish you with an inspection report and the necessary forms for filing the concealed-damage claim.

7.0 STATIC DISCHARGE PROTECTION

Components used in modern electronic equipment, especially solid state devices, are susceptible to damage from static discharge. The relative susceptibility to damage for semiconductors varies from low with TTL to high with CMOS. Most other

semiconductors fall between TTL and CMOS in susceptibility to static discharge.

As a minimum, therefore, observe the following practices when working inside this or any other electronic equipment:

1. Use conductive sheet stock on the work bench surface
2. Connect the sheet stock to ground through a 1 megohm or greater value resistor
3. Use a wrist strap connected to ground through a 1 megohm or greater value resistor when working at the bench
4. Maintain relative humidity of the room above 30 percent. This may require a room humidifier. Working on circuits when relative humidity is below 30 percent requires extraordinary procedures not listed here
5. Use anti-static bags to store and transport exposed chassis, circuit boards, and components. Use new anti-static bags. Old, used bags lose their static protection properties

This list serves as a reminder of the minimum acceptable practices. Be sure that all static discharge devices at the work bench are properly installed and maintained.

Standard grounding sheets and wrist straps purchased for use at work benches are supplied with leads having the required current limiting resistors for safety. Never substitute with a lead that does not have a resistor.

8.0 INSTALLATION PROCEDURE

This summary of the installation procedure assumes that the Camera may not be properly set up for the intended application. Internal jumpers may have to be repositioned and side panel controls may require new settings while the camera is at a work bench. The Camera is then turned on so that back focus (CS-mount adjustment) can be checked out before mounting at its permanent location. If the Camera is known to be properly set up for the intended application, only steps 8 through 11 need be performed.

Additional information about these procedures follows this summary of the installation procedure. Do not begin the installation without referencing the

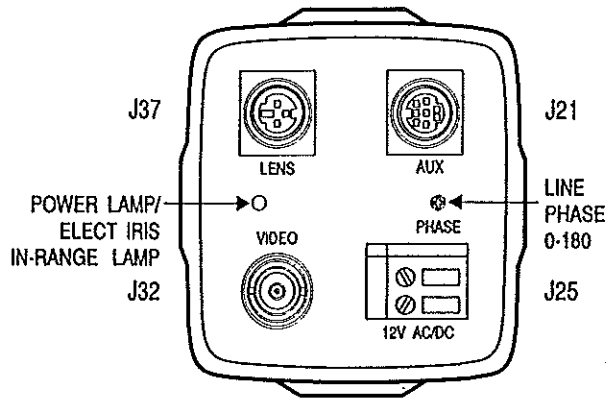

Figure 3. Rear Panel

subsequent sections that provide detailed instructions about the installation. Figure 3 shows the Camera rear panel, where all interconnections are made.

A typical installation includes:

1. Installing the required power, video, and auxiliary connector cables between the Camera location and the operator's console or equipment room.
2. Removing the case and setting up internal jumpers for the desired operating conditions
3. Installing the lens (and, for an auto iris lens, connecting the lens video cable).
4. Connecting power and video (and if required sync).
5. Checking back focus and adjusting the lens mount adapter if necessary.
6. Setting up side panel controls for the intended application (if required)
7. Removing power, video, and sync cables
8. Mounting the Camera at its location
9. Connecting power, video, and any other required cables.
10. Adjusting the Camera and lens to view the scene of interest.
11. Making any required final adjustments to side panel controls, the rear-panel line-lock PHASE adjustment, and the manual-iris lens if the electronic iris option is being used.

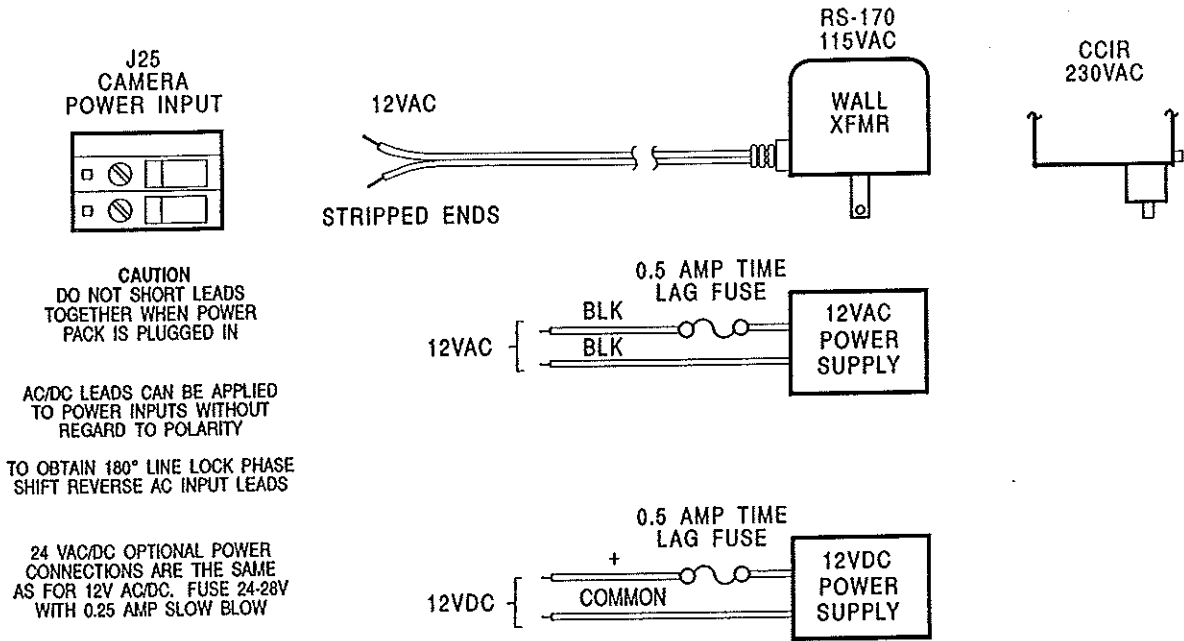

Figure 4. Power Supply

8.1 Power Connections

CAUTION
Do not apply voltage outside the recommended operating range of the Camera (12 V ac/dc ±10%, or 24 V ac / 24-28 Vdc ±10% for the optional version.)

The Camera requires either 12 V ac/dc, or optionally 24 V ac / 24-28 Vdc, ±10%. A 12-volt version of the Camera operates from 115 V ac, 60 Hz (or 230 V, 50 Hz) power by using an optional external plug-in

wall transformer (figure 4). If the Camera is to operate from a power supply other than the optional wall transformers, use a 0.5-amp time-lag fuse (0.25-amp time-lag fuse with the 24-volt version of the Camera).

When fluorescent lighting will be used to illuminate the scene being viewed by the camera during electronic iris operation, line lock mode must be used. This requires that the camera be operated from 12 V ac (or the optional 24 V ac) input power at the rear panel.

8.2 Video Connections

Standard 1-volt peak-to-peak composite video is available at the rear panel BNC connector (figure 5).

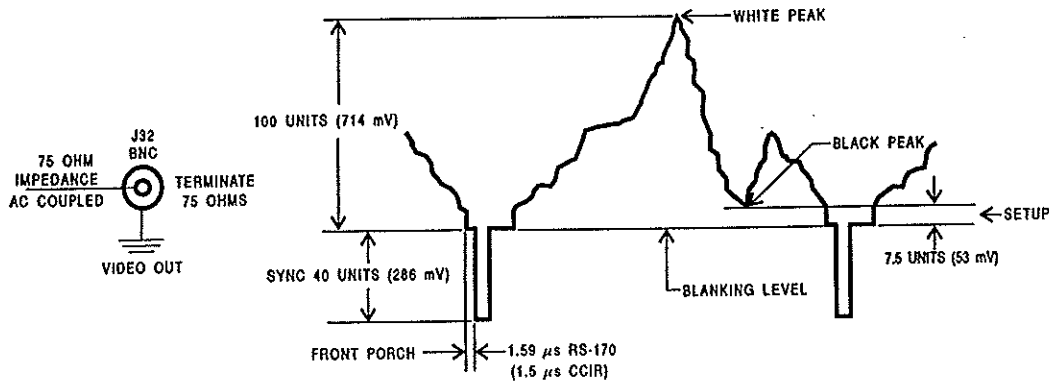

Figure 5. Video Output Connector (J32)

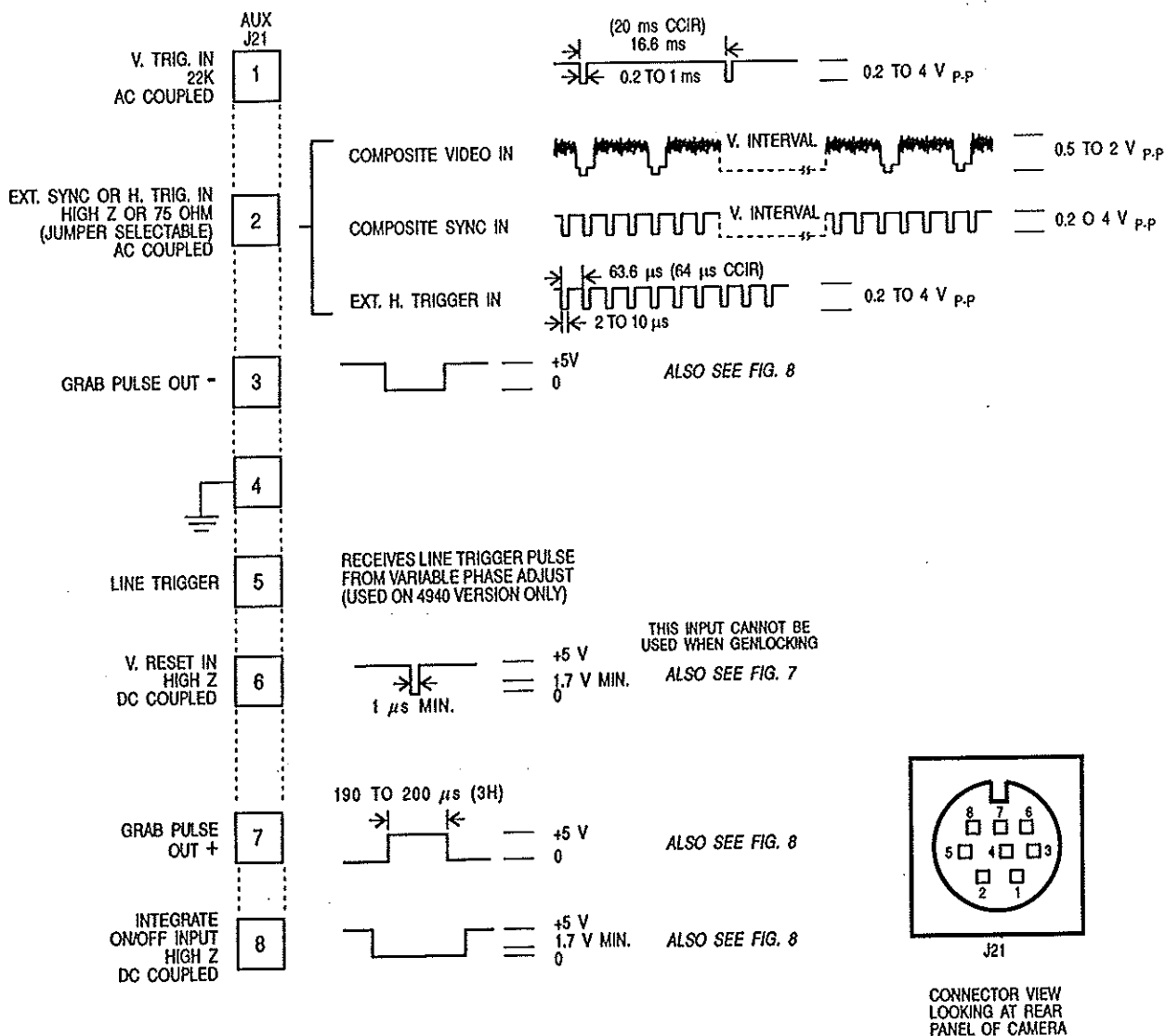

Figure 6. Auxiliary Connector (J21)

This is a standard 75-ohm ac coupled video output. Use 75-ohm coaxial cable. A 75-ohm termination must be used at the equipment connected to this cable. When multiple equipment is connected to the video output in a loop-through arrangement, only the last item of equipment at the end of the cable should be terminated. All other equipment must present a high impedance to the cable.

8.3 Genlock Inputs

Applying composite sync (sync containing both horizontal sync and vertical sync pulses) to pin 2 of the AUX connector (figure 6) takes control of the Camera away from the internal sync reference. (The internal reference is either the crystal or the line-lock reference. Line lock can be used only if the Camera is operating from low voltage ac at the rear panel.)

When the Camera genlock input is on a cable with other Cameras (or video equipment), only the Camera or equipment at the end of the cable away

from the sync source can have its internal 75-ohm termination selected. If the Camera is mid-cable in such an arrangement, be sure that jumper JB80 on the genlock/power-supply board is removed. Removing the jumper allows the input to become a high impedance instead of 75 ohms. This jumper can be stored by plugging it onto only one pin.

The Camera can also be connected to a sync reference consisting of horizontal-trigger pulses applied to pin 2 on the AUX connector and vertical triggering pulses applied to pin 1.

8.4 Asynchronous Input

Repositionable jumpers on the video/sync board must be positioned to RST (reset) when the asynchronous reset feature is to be used. It cannot be used if the jumpers are positioned to the NOR (normal) mode, which is genlock.

An asynchronous reset is initiated when pin 6 of the AUX connector is pulled low (below 1.7 volt). The vertical interval of the Camera then resets 2.5 microseconds later (figure 7). Note that the minimum allowable width of the reset pulse is 1 microsecond.

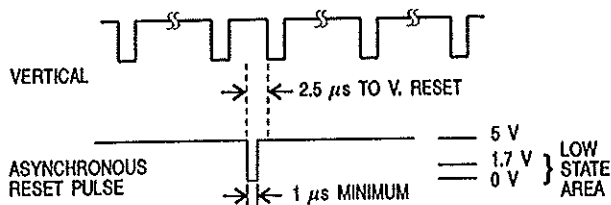

Figure 7. Timing Diagram, Asynchronous Vertical Reset

Since application of the reset pulse most likely interrupts the sensor before the end of an integration period, the first field of video out of the Camera following reset will be of a reduced video level. (If operating in the interlaced frame mode, the second field will also have a reduced level.) Subsequent fields would then be of normal video levels.

8.4.1 Strobing with Asynchronous Input

To capture rapidly moving or periodic events, a strobe light can be used in conjunction with an asynchronously reset.

The camera should be operated in frame mode so that both fields are produced by the strobe. See section 13 for a description of field and frame modes.

This strobe can occur during either of two periods (figure 8) following application of the reset pulse:

1. Beginning 2.5 μ s after application of the reset pulse and throughout a 9 horizontal-line interval (14.5 H for CCIR) until a transfer gate occurs. This is a strobing window of about 572 (928) microseconds.

2. Beginning 9.5 H (15 H for CCIR) after the vertical drive is reset and continuing throughout a full vertical interval — 1/60 (1/50) second — until the next transfer gate occurs.

Figure 8 also shows the related fields of video produced by a strobe during either of these two strobe periods.

Captions accompanying the waveform in figure 8 more fully describe their relationships. For a detailed view of the 2.5 μ s delay between application of the asynchronous reset pulse and the start of a new vertical drive see figure 7. It expands this timing area to show both the 2.5 μ s delay and the required 1 μ s minimum duration for the asynchronous reset pulse.

Ambient Light Considerations — When planning to use a strobe light with the camera, some consideration should be given to ambient lighting on the scene and to the setting of the lens iris. When the camera is asynchronously reset, any image integrated on the sensor up to that time becomes part of the video output. This will be both fields if in frame mode and a single field if in field mode.

Ideally the camera should not produce any picture unless the strobe is triggered. This would require a nearly dark scene. As a practical matter, it is likely that some picture can be allowed to appear before it produces unacceptable interference with the strobe light image. A few tests will determine whether the image generated by ambient light produces unacceptable interference with the desired strobe light image.

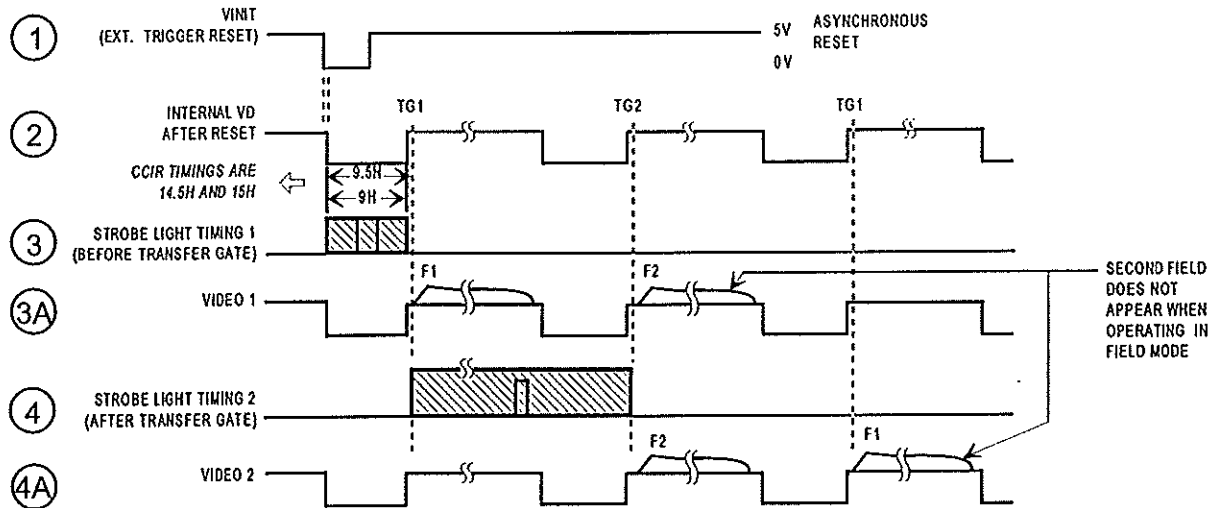

NOTE: The following descriptions assume operation in frame mode. Since frame mode integrates both the odd and even fields simultaneously, a strobe of light produces a complete frame of video. (In field mode, however, odd and even fields are produced during separate vertical intervals; only a single field of video can result from a strobe.)

- ① **ASYNCHRONOUS RESET PULSE** When this pulse is applied to pin 6 of J21, on the camera rear panel, the camera internal vertical drive resets. See waveform 2. (Though not detailed on this figure, a delay of 2.5 μ s occurs between application of the reset pulse and internal vertical drive being reset. See figure 7 for an expanded view.)
- ② **CAMERA INTERNAL VERTICAL DRIVE RESET.** When the camera internal vertical drive is reset, two time periods follow during which a strobe light may be triggered to illuminate the scene. In frame mode, both fields will be integrated by the sensor when this strobe occurs during either period.
The first period starts 2.5 μ s after reset and continues for 9 H (14.5 H for CCIR) lines. The shaded area in waveform 3 shows this first period.
A transfer gate occurs in the interval reserved from 9 to 9.5 lines (14.5 to 15 lines for CCIR). This gate (TG1) initiates transfer of field 1 and then a second gate (TG2) initiates transfer of field 2 from the sensor to become video at the Camera rear panel BNC connector, J32. This is shown in waveform 3A. Be aware that ambient light on the scene may produce sufficient video to interfere with the image produced by the strobe.
The second period starts 9.5 H lines (15 H lines for CCIR) after reset and continues for a full vertical interval of 1/60 (1/50) second. See waveform 4. The transfer gate at the end of this vertical interval then initiates movement of field 2 from the sensor to become video at the Camera rear panel BNC connector, J32. A second gate initiates movement of field 1 to this output. Waveform 4A shows field 2 followed by field 1. Vertical intervals and transfer gates then repeat until another asynchronous reset pulse is applied at pin J21-6.
- ③ **FIRST STROBE PERIOD.** After application of the asynchronous reset pulse and throughout an interval of 9 H lines (14.5 H lines for CCIR), the strobe light may be triggered to light the scene. Field 1 and field 2 are integrated simultaneously by the sensor. This results in the outputs shown in Waveform 3A.
- ③A **OUTPUT FROM FIRST STROBE PERIOD.** Both fields are integrated by the sensor when the strobe is triggered during the first 9 H intervals (14.5 H intervals for CCIR) after asynchronous reset. TG1 transfers out field F1 and TG2 transfers out field F2 to provide video at the camera rear panel. Both fields may have residual image from ambient light.
- ④ **SECOND STROBE PERIOD.** This period begins 9.5 H intervals (15 H intervals for CCIR) after asynchronous reset and continues throughout a full vertical period of 1/60 (1/50) second. A strobe light triggered anytime during this period produces both fields on the sensor simultaneously. Waveform 4A shows the video outputs derived from the sensor as a result of a strobe light being triggered during this second period.
- ④A **OUTPUT FROM SECOND STROBE PERIOD.** When the scene is strobed with light during the second strobe period, the first video out of the camera is field F2 — followed by field F1. Both fields may have residual image from ambient light.

Figure 8. Timing Diagram, Asynchronous Reset with Strobe Light Intervals

8.5 Integration Input and Output

When pin 8 of the AUX connector is pulled low, integration begins with the next vertical blanking pulse. When the input is allowed to go high again, integration ends with the next vertical blanking pulse. Note in figure 9 that integration begins and ends with the vertical blanking interval — not at the exact time of application and removal of the integration pulse. The minimum integration period is two fields. The maximum period is about four to six seconds, limited by deterioration of picture quality caused by dark current. It is best to perform tests to determine acceptable picture quality vs. integration period for an intended application.

For applications requiring longer integration periods, maintaining the Camera (sensor) at reduced temperatures will enhance picture quality by reducing noise.

8.6 Lens Installation

Figure 10 shows spacing of a CS-mount lens and a C-mount lens in relation to the focal plane of the sensor. Note that the 5-mm adapter ring positions the mounting shoulder of a C-mount lens 5 mm farther away from the sensor. A CS-mount lens focuses 12.5 mm away from its shoulder. A C-mount lens focuses 17.5 mm away.

The mounting shoulder is the surface of the lens that presses against the mounting adapter when it is fully threaded in.

If a CS-mount lens is to be installed, be sure that the 5-mm extension ring has been removed. For installation of a C-mount lens, be sure the 5-mm ring is in place. Proceed as follows:

1. Remove the protective plastic plug or seal from the lens mount adapter opening.

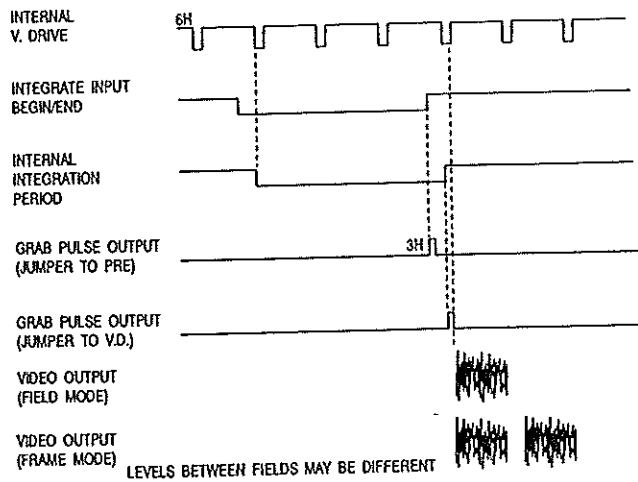

Figure 9. Timing Diagram, Integration

2. Clean the lens and the window in front of the image sensor. Use methyl alcohol or a commercially prepared optical-quality solution and a cotton swab. Never rub an optical surface with a dry swab.

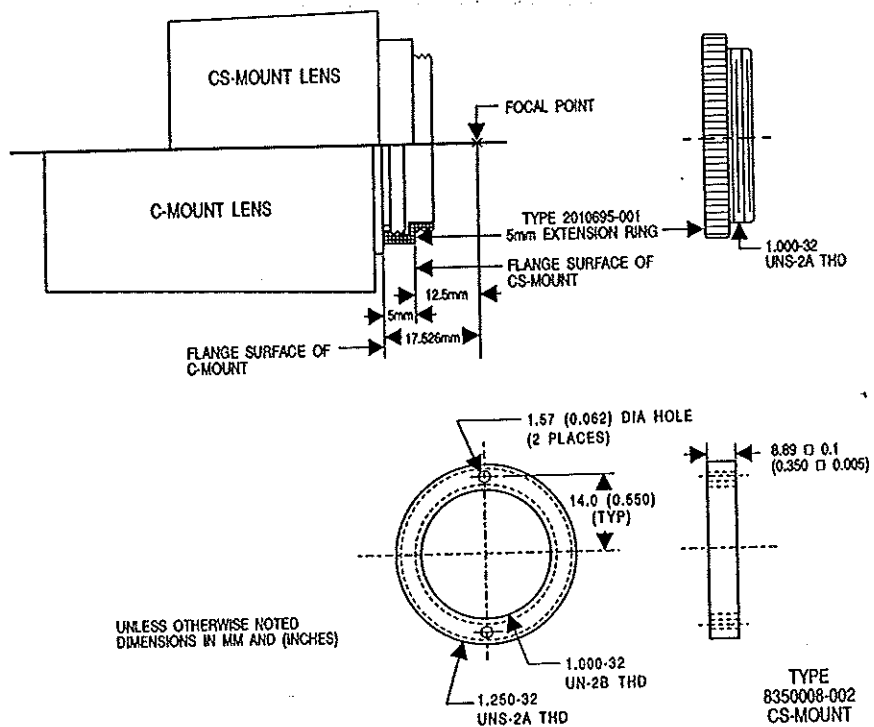

Figure 10. CS and C-Mount Adapters

NOTE

The window in front of the sensor faceplate is out of the focal plane of the Camera. Thus small contaminants on this surface will most likely not show up in the picture. Even so, pressurized dry air should be used to remove any contaminants on the window or IR filter.

3. Check the setscrew and make sure it is snugged down. Be careful not to over-tighten.
4. Screw the lens into the adapter. Snug down so the two will turn as one unit when the setscrew is loosened for focus adjustments.
5. If an auto lens is used, plug the lens cable (P37) into the lens connector (J37) on the rear panel (figure 11).

8.7 Back Focus Adjustment

Back focus adjustment establishes proper distance between the back of the lens and the sensor. This ensures that the lens projects its image exactly on the surface (focal plane) of the sensor and not slightly in front of or behind the surface.

This distance is set by observing for sharp focus on a picture monitor. The lens focusing first must be set to infinity and the iris fully opened to establish minimum depth of field.

The adjustment can be performed either with a CS-mount lens installed in the CS-mount adapter or with a C-mount lens and 5-mm adapter installed in the CS mount.

Once back focus is set, it should be possible to change between most lens types without any further setting of back focus.

The first four steps determine whether any adjustment is required. Proceed as follows.

1. Set the lens focusing ring to infinity.
2. Point the Camera at a distant scene well into the infinity focusing distance of the lens.
3. Place sufficient neutral density (ND) filters in front of the lens so the lens iris is fully open with normal video output.
4. Note whether the scene is in sharp focus. If it is, no adjustment is required.

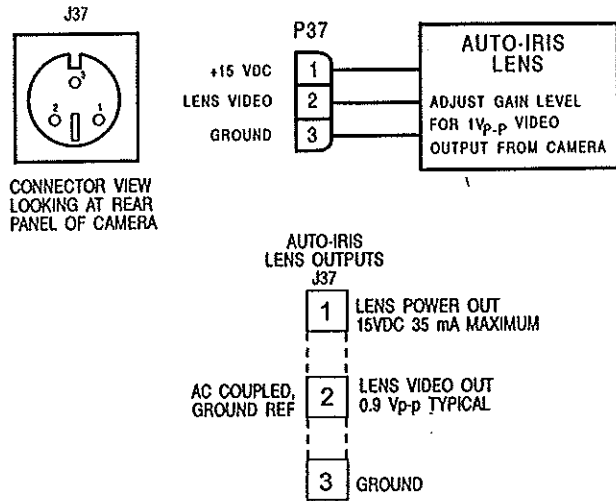

Fig. 11. Auto Iris Lens Connectors

5. If the scene is out of focus, loosen the setscrew and rotate the lens and adapter as a unit in and out of the Camera until the scene is in focus.
6. Snug down the setscrew. Do not over-tighten.
7. Verify that sharp focus is still maintained.

8.8 Auto Iris Lens Level

If an auto iris lens is used and the scene on a picture monitor has too much or too little contrast (or pulsates/hunts) under bright lighting conditions, the LEVEL control on the lens may require adjustment. To adjust this control, proceed as follows:

1. Set the side panel AGC switch to ON.
2. Set the auto iris lens PK/AVG (peak/average) control fully toward AVG.
3. Point the Camera at a brightly lighted scene having a full range of white and black levels.
4. Adjust the LEVEL control on the lens to obtain a normal picture on the picture monitor. When this control is properly set, video output at J32 to the monitor should be 1 V_{p-p}.

Note: (Lens manufacturers typically label this control LEVEL. If a lens is being used that does not have a control labeled LEVEL, adjust the control with a name similar to this function.)

Table 4. Side Panel Adjustments

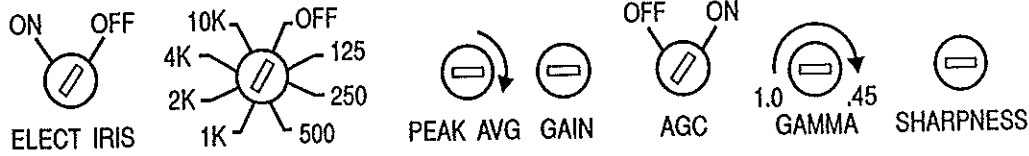

CONTROL NAME	NORMAL SETTING	FUNCTION
ELECT IRIS ON/OFF (Requires the optional electronic Iris board and a manual-iris lens)	ON	When turned ON, the electronic iris board provides automatic control of camera sensitivity to scene lighting through a range of about eight f/stops. It does this by electronically shuttering the sensor in the camera through a continuous range from 1/60 (1/50) second to 1/15,000 second. The Iris on the manual-iris lens must be properly set. See section 12.0 for this adjustment. When the ELECT IRIS switch is set to ON, the eight-position shutter speed switch to the right is deactivated.
Shutter Speed Switch	1/60 (1/50)	Sets the shutter speed of the camera to any of its eight settings: from 1/60 (1/50) up to 1/10,000 second. Active only when ELECT IRIS switch at left is set to OFF
PEAK/AVG	Midrange	When the related AGC ON/OFF switch is set to ON, this peak/average control determines whether the automatic gain control circuits respond more to peaks (highlights) of light in the scene or to the overall average light level. When this control is rotated toward the PEAK position, the agc holds the peaks in the video to a maximum of 100 IRE units. When adjusted to the AVG position, the agc averages the video to the 100-unit level.
GAIN	Midrange	When the related AGC ON/OFF switch is set to OFF, this control provides a manual gain control range of 20-dB for the camera. To minimize noise in the video, keep this control toward ccw. To increase gain (sensitivity to light), rotate this control clockwise. Noise increases as the control is rotated cw for more gain.
AGC ON/OFF	ON	Setting this switch to ON provides automatic gain control. Agc range is 20 dB. Setting the switch to OFF activates the related manual GAIN control.
GAMMA 1.0 / 0.45	0.45 for viewing 1.0 for measurement	Rotated fully cw to 0.45, this control provides a nonlinear video output that favors black areas of the scene at the expense of white areas. This setting compensates for a nonlinear characteristic common to all vacuum-type picture tubes used in standard monitors. Picture tubes favor whites over blacks. The net effect is that blacks and whites in the scene are accurately represented visually. This gamma control can be used to change tonal variations between blacks and whites when viewing scenes on a monitor. As the control is rotated ccw, away from the 0.45 position, the camera video output becomes less and less nonlinear. At the full ccw position (1.0) the video output is linear. Blacks and whites are represented electronically exactly as they appear in the scene. This is the setting to use for measurement purposes. Use 1.0 when connecting a frame grabber to the video output.
SHARPNESS	CCW	When adjusted clockwise, this control causes the peaks of the video signal to "ring", or oscillate. This increases the contrast between the black/white and white/black transitions of the video signal. Adjust this control while viewing a monitor displaying camera video until the desired amount of sharpness is reached.

Table 5. Repositionable Jumpers

JUMPER	PURPOSE
VIDEO/SYNC BOARD	
JB1 XTAL/LL	Jumper position determines whether the default internal sync source is the internal crystal —RS-170(A) or CCIR—or the low voltage ac input power. Input power at the Camera rear panel connector must be ac for line lock to be used. A Camera operating with a genlock sync source will revert to either crystal or line lock (with ac input power) upon removal of the genlock input.
JB2, JB3 NOR/ RESET	Positioning JB2 to NORmal selects genlock as the external sync source by activating pins 1 and 2 of the rear panel AUX connector. Positioning JB2 to RST activates the asynchronous vertical reset input (pin 6) of the rear panel AUX connector. In asynchronous mode, the Camera can be reset at any time by pulling pin 6 low. The Camera then provides video output immediately following a vertical blanking interval. Jumper JB3 is typically set to RST at all times. If desired it can be positioned to NOR when JB2 is set to NOR.
JB4 FRAME/ FIELD	FIELD mode is the normal mode. In FIELD mode the sensor integrates for 1/60 (1/50) second. Two lines are summed and read out at a time until all pixels are read out. Although this reduces vertical resolution, it also minimizes lag and improves sensitivity. In FRAME mode, the sensor integrates for 1/30 (1/25) second and readout is the same as for a tube Camera. One row of pixels is read out for each horizontal line. FRAME mode gives the highest resolution, but lag and sensitivity are somewhat degraded.
JB5 Auto Black On/Off	When set to On, black level is maintained at 7.5 ± 5 IRE units when the scene contains at least 10 percent black. With less than 10% black the circuit will attempt to pull the darkest area of the scene (even white) to the black level; this can cause a monitor screen to go black and interfere with operation of an auto iris lens.
JB6 (Comp / Non-Comp)	Selects whether the auto lens video signal is composite (has sync) or non-composite. This setting is dependent on the type of lens used. Installing the jumper selects composite lens video.
GENLOCK/POWER SUPPLY BOARD	
JB60 VD/PRE	This jumper position determines where the integration grab-pulse output begins. See figure 9. When positioned to PRE, the grab pulse starts at the same time the integration start/stop pulse goes low to end integration. Note in figure 9 that the integrated output from the Camera begins with the first vertical interval after leading edge of the grab pulse. When the jumper is positioned to V.D. (vertical drive), the grab pulse starts at the same time actual integration is ended. The grab pulse is coincident with the vertical-drive pulse at the end of integration.
JB80 75 Ohm Sync Sel.	With this jumper installed, the external sync/horizontal-trigger input (pin 2 of the AUX connector) is terminated with 75 ohms. This jumper should be removed only when the Camera is to be installed in a genlock cable with other Cameras. In this situation, only the last Camera (or other type of equipment) at the far end of the cable is terminated with 75 ohms. The disconnected jumper can be stored by installing it on only one pin of JB80. †

5. Vary light level into the camera by placing a hand in front of the lens and taking it away. Do this several times while observing the picture monitor.

6. Note whether the light level of the scene on the picture monitor pulsates or hunts after the hand has been taken away. If pulsating/hunting is

noted, proceed to step 7 for adjustment. If scene lighting remains stable, proceed to step 9.

7. Adjust the PK/AVG control on the auto iris lens slightly toward PK and repeat steps 5 and 6 until the pulsating/hunting stops. If it persists after several slight adjustments to the PK/AVG control, proceed to step 8.

FRAME SCANNING		INTERLACE	NON-INTERLACE
INTEGRATION TIME VS. VIDEO OUT (ON-TYPICAL SHUTTER) 	INTEGRATION TIME		
	VERTICAL DRIVE		
	VIDEO OUT		
SENSITIVITY		NORMAL	ONE-HALF NORMAL
VERTICAL RESOLUTION - TV LINES		485(575)	242(287)

NOTE: WHEN ASYNCHRONOUSLY RESETTING WITH THE SHUTTER ON IN FRAME MODE, VIDEO OUTPUT OCCURS IN 1/60(1/50) SECOND.

Figure 14. Frame Integration Mode

FIELD SCANNING		INTERLACE	NON-INTERLACE
INTEGRATION TIME VS. VIDEO OUT (ON-TYPICAL SHUTTER) 	INTEGRATION TIME		
	VERTICAL DRIVE		
	VIDEO OUT		
SENSITIVITY		NORMAL	NORMAL
VERTICAL RESOLUTION - TV LINES		350(450)	242(287)

Figure 15. Field Integration Mode

10.0 INTERNAL ADJUSTMENTS

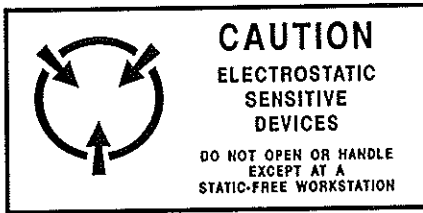

Six repositionable jumpers are accessible when the case is removed from the Camera. Table 5 lists these jumpers and describes their functions. Their locations on the video/sync and genlock/power-supply boards are shown in figures 12 and 13.

Do not make any adjustments to components on the circuit boards when the case has been removed to reposition a jumper. Performing internal setup adjustments requires test instruments and detailed step-by-step procedures. Such procedures appear in section V of the Installation, Operation, and Maintenance Manual (6X-925). Perform internal setup adjustments only when the step-by-step procedures in that manual are being followed. Be aware that adjusting anything electrical or mechanical without the proper procedure may void the warranty of a new Camera. Refer to the last page of this manual for the warranty.

11.0 REAR PANEL LINE-LOCK PHASE ADJUSTMENT

Multiple Cameras operating from 12 (or the optional 24) V ac input power can have their vertical intervals locked together by using the power line frequency as a reference. The internal crystal/line-lock (XTAL/LL) jumper on the video/sync board of all Cameras must be positioned to LL to use this feature.

Several situations can cause Cameras not to have their vertical intervals occurring at the same time when all are locked to the ac input power at the Camera rear panel.

1. Power input at the Camera rear panel may be 180 degrees out-of-phase relative to the Camera chosen as the reference. This is because the two leads at the power input connector are reversed in relation to the reference Camera.

2. Some Cameras may be operating off different phases of the main power line. This could position vertical intervals out-of-phase by, for example, 180 degrees or even 120 or 240 degrees relative to the power line.

3. Other phase shifts in power distribution equipment may be significant enough to cause problems in some applications.

Two actions can be performed at each Camera to put its vertical interval in phase with the vertical interval chosen as reference. (1) The rear panel PHASE control can be adjusted to provide up to 180 degrees of control. (2) If more than 180 degrees is required, the two power input leads can be reversed for a 180-degree phase shift. Then adjust the rear panel PHASE control for the final amount required.

The adjustment is generally done by observing video at the switcher where all the video cables converge. Use a dual-channel oscilloscope.

Video from one Camera is selected as the reference. Then the input power leads and PHASE controls on all other Cameras are changed as necessary to bring their vertical intervals into alignment with the reference Camera.

In summary, then:

1. Adjust the rear panel PHASE control for up to 180 degrees of control
2. Switch the two power leads at the rear panel when more than 180 degrees of control is required. Then make a final adjustment with the PHASE control.

12.0 ELECTRONIC-IRIS/ MANUAL-IRIS-LENS SETUP

When turned ON, the optional electronic iris board provides automatic control of Camera sensitivity to scene lighting through a range of nearly eight f/stops. It does this by electronically shuttering the sensor in the Camera through a continuous range from 1/15,000 second (scene very bright) to 1/60 (1/50) second (scene not well lighted). The manual-iris lens must be set to bring the light handling capability of the electronic iris within range of the sensor.

For indoor use where scene lighting typically is not extremely bright and does not vary more than

seven f/stops, the iris on the manual lens can usually be set wide open.

If fluorescent lights illuminate the scene, use line lock mode to prevent interference with the electronic-iris circuits.

For viewing a scene where the light is extremely bright and can vary more than seven f/stops (such as an outdoor scene), the iris on the manual lens must be stopped down somewhat. This is to bring the light reaching the sensor into a range that the electronic iris can handle. Proceed as follows to make this setting:

1. Verify that the Camera is viewing the scene of interest and that no further positioning adjustments are required.
2. Wait for the brightest time of day on the scene being viewed by the Camera.
3. Open the manual iris fully while observing the indicator lamp on the rear panel (fig. 3). As the lens is opened this lamp should go out at some point, indicating that the electronic iris has run out of range (and thus is at 1/15,000 s).
4. Slowly close the lens iris until the rear panel indicator just comes on again. This is the proper setting for the manual iris lens.

If blooming is observed on the picture monitor while using the electronic iris feature, it is likely that scene lighting has become too bright for the electronic iris circuit.

13.0 OPERATING MODES

The four basic scanning modes are:

- Frame mode, interlaced
- Frame mode, non-interlaced
- Field mode, interlaced
- Field mode, non-interlaced

The Camera can be operated with non-interlaced scanning only when externally applied horizontal and vertical drive are used to establish a non-interlaced condition.

Timings appear first as RS-170 followed by CCIR timings in parenthesis.

Note in the two illustrations that a shutter interval is shown together with the integration time for

fields 1 and 2. The long line is the integration time without shuttering. The boxed portion at the end of the long integration line is a representative integration period for shutter mode. The key point is that shuttering occurs near the end of a vertical interval.

13.1 Frame Mode — Interlaced

Refer to figure 14. In the interlaced frame mode, the sensor integrates each field for 1/30 (1/25) second — spanning two vertical intervals. Note that field-2 begins integrating midway through the integration of field-1.

Field-1 is comprised of odd lines, field-2 of even lines. In this mode pixels are not paired to form lines. Thus the maximum vertical resolution of about 485 (575) tv lines is available.

Since this mode integrates each field for 1/30 (1/25) second it is more prone to problems with relative movement between the Camera and scene.

13.2 Frame Mode — Non-interlaced

Refer to figure 14. Each field is scanned for 1/60 (1/50) second. Each field is integrated on the sensor during its own interval.

Only the odd lines are used. Vertical resolution is about 242 (287) tv lines. This is about one-half that available with the frame interlaced mode.

This mode has about one-half the sensitivity of the other three modes. Reduced sensitivity results due to the combination of integration occurring for 1/60 (1/50) second and pixels not being combine.

In the other three sensor operating modes, normal specified sensitivity is maintained due either to 1/30 second integration or to two lines of pixels being combined to form a single line.

13.3 Field Mode — Interlaced

Refer to figure 15. In the interlaced field mode, the sensor integrates for 1/60 (1/50) second and combines two rows of pixels to form the lines.

Note that to form field-1, pixels in lines one and two are combined. Then to form field-2 pixels in lines two and three are combined.

Because two lines of pixels are being combined to form each line, this mode provides the normal specified sensitivity, but it has less vertical resolution than the interlaced frame mode.

This mode has less lag than the interlaced frame mode because of its 1/60 (1/50) second rate.

13.4 Field Mode — Non-interlaced

Refer to figure 15. In the non-interlaced field mode, the Camera operates at a 1/60 (1/50) second rate. The same two rows of pixels are combined to produce each line for both fields. This results in the lower vertical resolution of 242 (287) tv lines. Because two lines of pixels are combined to form each line, though, normal specified sensitivity is obtained.

14.0 PREPARATION FOR SHIPMENT AND STORAGE

For storage periods exceeding about one month, seal the unit in a vapor-proof bag containing a fresh desiccant pack. Maintain the Camera storage environment within a range of -30 to 70 °C (-22 to 158 °F).

For shipment, package with enough foam padding or other packing material to prevent damage



that can occur during shipping. The original shipping carton is a good container if it has not been damaged or subjected to excessive moisture.

For shipping to the factory by Common Carrier, use 3912 Calle Fortunada, San Diego, CA 92123-1827 as the address. Please contact the Customer Service Department for a Return Authorization (RA) number before sending any shipments to the factory.

WARRANTY

Cohu, Inc., Electronics Division, warrants equipment manufactured to be free from defects of material and workmanship. Any part or parts will be repaired or replaced when proven by Cohu examination to have been defective within two years from date of shipment to the original purchaser for standard CCD cameras and one year from date of shipment to the original purchaser for intensified CCD cameras and all other Cohu manufactured products. All warranty repairs will be performed at the factory or as otherwise authorized by Cohu in writing. Transportation charges to Cohu shall be prepaid by purchaser.

This warranty does not extend to Cohu equipment subjected to misuse, accident, neglect, or improper application, nor repaired or altered by other than Cohu or those authorized by Cohu in writing. **Television image pickup tubes, image intensifiers, lenses, and products manufactured by companies other than Cohu are warranted by the original manufacturer.**

This warranty is in lieu of all other warranties expressed or implied. Cohu shall not be liable for collateral or consequential damages.

A Return Authorization (RA) number must be obtained from Cohu prior to returning any item for warranty repairs or replacement.

January 29, 1999
Rev. 1. 10-1-99

COHU
Cohu, Inc. Electronics Division